

DAMIAOAO | 达妙科技

DM-H65-1EC Hub Motor Kit

User Manual V1.0 2025.11.25



Disclaimer

Thank you for purchasing the DAMIAOAO DM-H65-1EC Motor Kit (including DM6540-1EC driver) (hereinafter referred to as "Motor" and "Driver" respectively for DM-H65-1EC motor and DM6540-1EC driver). Before using this product, please carefully read and follow this document and all safety guidelines provided by DAMIAOAO Technology. Failure to do so may cause harm to you and surrounding Homo sapiens, or damage to this product or other surrounding items. By using this product, you are deemed to have carefully read this document, understood, acknowledged, and accepted all terms and contents of this document and all related documentation of this product. You agree to use this product solely for legitimate purposes. You accept full responsibility for the use of this product and any consequences that may arise. DAMIAOAO Technology shall not be liable for any damage, injury, or legal liability resulting directly or indirectly from the use of this product.

DAMIAOAO is a trademark of Shenzhen DAMIAOAO Technology Co., Ltd. All product names and brands mentioned in this document are trademarks of their respective companies. This product and manual are copyrighted by Shenzhen DAMIAOAO Technology Co., Ltd. Unauthorized reproduction or reprinting in any form is prohibited. The final interpretation rights of this document and all related documentation of this product belong to Shenzhen DAMIAOAO Technology Co., Ltd. Updates may be made without prior notice.

Precautions

Strictly adhere to the specified working environment and the maximum allowable temperature range for windings when using the motor, otherwise it will cause permanent and irreversible damage to the product.

Avoid foreign objects entering the interior of the rotor, as this may lead to abnormal operation of the rotor.

Before use, inspect all components to ensure they are intact. If any parts are missing, aged, or damaged, discontinue use immediately.

Ensure correct wiring and proper, secure installation of the motor.

Do not touch the electronic rotor during operation to prevent accidents. When the motor outputs high torque, heating may occur—take care to avoid burns.

Users must not disassemble the motor without authorization, as this may affect the motor's control accuracy or even cause abnormal operation.

Due to the motor's high moment of inertia, avoid sudden power cuts during high-speed rotation. Instead, stop the motor by turning off the power or adjusting control parameters.

Motor Features

High-precision/high-resolution encoder.

The motor and driver adopt a split design, allowing direct replacement of the driver without the need for recalibration or parameter adjustment.

Supports host computer visual debugging and CAN read/write parameters.

Supports CAN FD with a maximum baud rate of 5 Mbps.

Can feedback motor speed, position, torque, and motor temperature via CAN bus.

Equipped with dual temperature protection.

Supports CAN-based firmware upgrades.

Specifications

Use the motor properly according to the following parameters.

Motor Parameters	Rated voltage	24V/36V/48V
	Rated phase/power current	9.4A/5.10A@24V 9.4A/3.45A@36V 9.4A/2.56A@48V
	Peak phase/power current	33.6A/21.55A@24V 33.6A/14.00A@36V 33.6A/10.40A@48V
	Rating torque	6.0Nm
	Peak torque	21.5Nm
	Rated speed	120rpm
	No-load maximum speed	260rpm@24V 395rpm@36V 480rpm@48V
Motor Characteristics	Number of slots	27
	Bumber of pole-pairs	15
	Phase inductance	750uH(@25°C)
	Phase resistance	420 Ω (@25°C)
Structure & Weight	External diameter	171mm
	Altitude	66.3mm
	Motor weight	Approximately 3150 grams
Encoder	Encoder bit count	17 people
	Encoder accuracy	±0.05 degrees
	Number of encoders	1
Communication	Control interface	CAN@5Mbps(Max)
	Parameter passing interface	UART@921600bps

Control & Protection	Control model	MIT mode
		Speed mode
		position mode
		hybrid mode of power and position control
	Protect	Enable over-temperature protection with a protection temperature of 120° C. The motor will exit the enable mode if overheated.
		Motor over-temperature protection. Set according to usage requirements, recommended not to exceed 100° C. The motor will exit the 'enabled mode' if overheated.
		Motor overvoltage protection. Set according to usage requirements, recommended not to exceed 65V. Overvoltage will exit the 'enabled mode'.
		Communication loss protection. If no CAN commands are received within the set period, the system will automatically exit the enable mode.
		Motor overcurrent protection. Set according to usage requirements. It is recommended not to exceed 0.98. Overcurrent will exit the "enabled mode".
		Motor under-voltage protection: If the power supply voltage drops below the set value, the system exits the enable mode. The power supply voltage must not be lower than 20V.

Operating Voltage

The operating voltage range is 24V-48V. Avoid hot plugging when exceeding 36V. The minimum operating voltage is 20V, and the maximum is 65V.

Maximum Phase Current

The maximum phase current of the corresponding drive can be queried by printing information through the serial port during power-on.

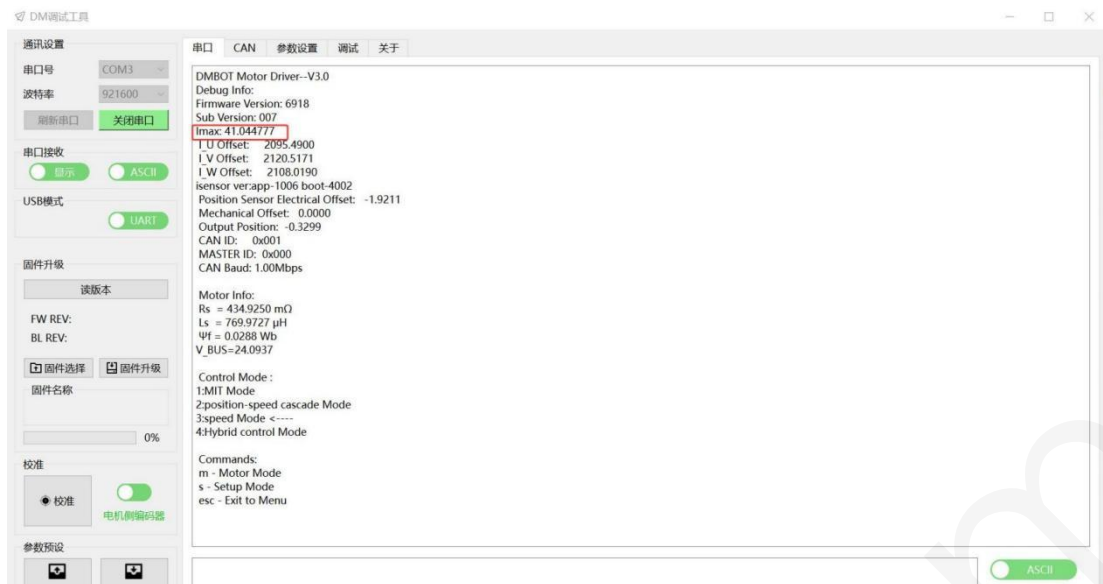

You can set the maximum phase current percentage to limit the operation through the debug assistant. The default value is 0.8, which is 80% of the maximum current that can be sampled. It is recommended that this value does not exceed 98%.

Encoder Version

When powered on, the serial port can print information to check the current motor encoder version. Here, 'isensor' refers to the motor encoder, 'app' is the version number, and 'boot' indicates the bootloader sequence number.

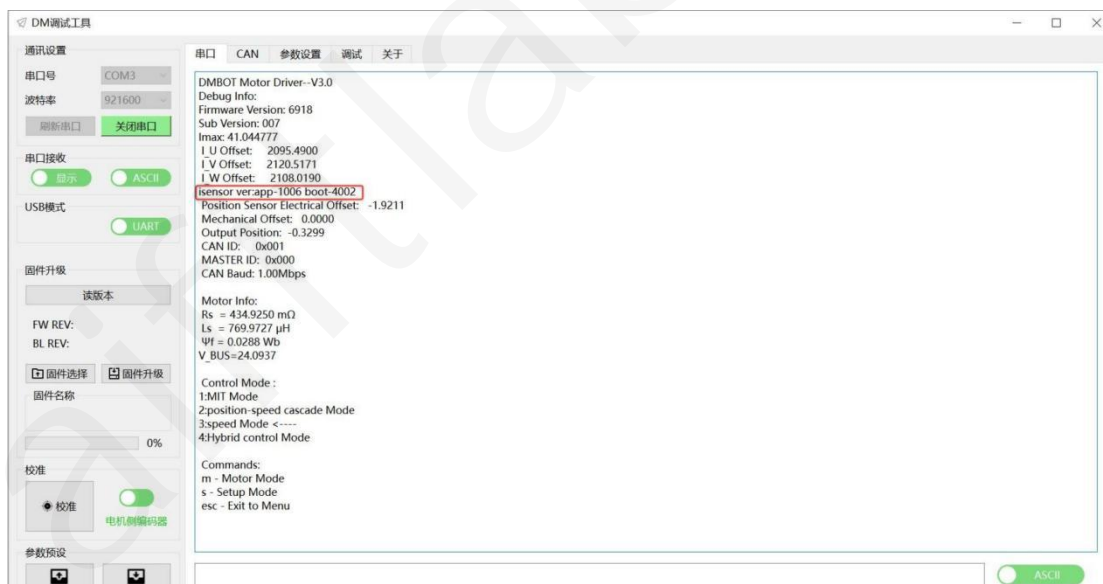

Maximum Speed

The maximum rotational speed is constrained by multiple factors, including power supply voltage (V_{BUS}) and magnetic flux density (ψ_f), with an upper limit typically calculated using the following formula.

$$V_{MAX}(rad/s) = 0.57735 * \frac{V_{BUS}}{N_{pp} * \psi_f} (rad/s)$$

In the formula:

V_{BUS} is the power supply voltage.

N_{pp} is the number of pole pairs in the motor.

ψ_f denotes the rotor magnetic flux.

Torque Constant

The torque coefficient of the motor can be considered constant within its rated range. When combined with the gearbox, the calculation can be performed using the following formula:

$$K_t = 1.5 * N_{pp} * \psi_f$$

among ,

N_{pp} : number of pole-pairs

ψ_f : rotor magnetic flux.

Package Contents

1. Motor × 1
2. Power cable: Single-ended XT30 plug cable (200mm) × 1
3. Debugging the serial signal line: GH1.25 connector-3-pin (crossed pins, 300mm) × 1
4. CAN communication terminal: GH1.25 connector-2-pin (crossed pins, 300mm length) × 1
5. Drive × 1

Interface and Pinout Description

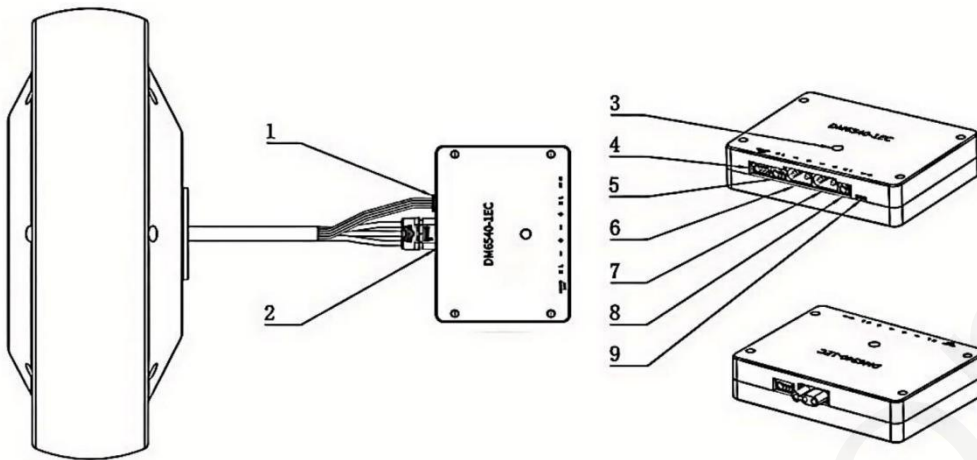

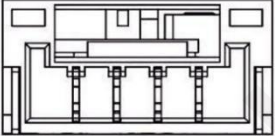
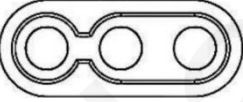
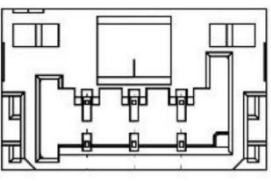
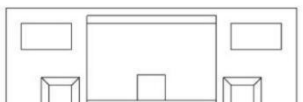
Designation - No.	Interface Label	Description
Encoder Interface (1)		Connects to the DM-H65-1EC motor using the matching 4-pin cross-type cable.
Three-phase line interface (2)		The three-phase wire of the motor is connected to the drive interface.
Motor indicator light (3)	not have	<p>Red light always on: The motor is in an inactive state</p> <p>The green light is always on: the motor is enabled</p> <p>Red light flashing: Motor error. Check the feedback frame for details.</p>
Debug Serial (4)	 GND RX TX	Connect the motor to the PC using the GH1.253-pin cable with a USB-to-CAN diagnostic tool (or a universal USB-to-serial module), then configure parameters and perform firmware upgrades via DAMIAOao Technology's diagnostic assistant.
Debug CAN port (5)		The GH1.25 connector with 2-pin interface enables external control devices to receive CANbus

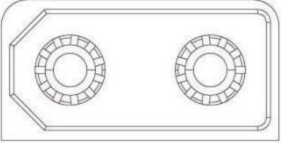
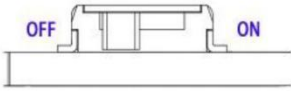
Debug CAN port (8)		commands and transmit motor status data.
Power interface (6)	 <p style="text-align: center;">GND VCC</p>	1. Connect the power supply to the XT30 plug via the power cable, with a rated voltage of 24V to power the motor.
Power interface (7)		2. The motor drive features two power interfaces, each supporting independent operation or multi-unit serial connection for streamlined wiring.
Terminal resistance switch (9)		The terminal resistance of the motor configuration is enabled by default.

Motor and Driver Size and Installation

Refer to the mounting hole dimensions to install the motor and driver on the corresponding equipment.

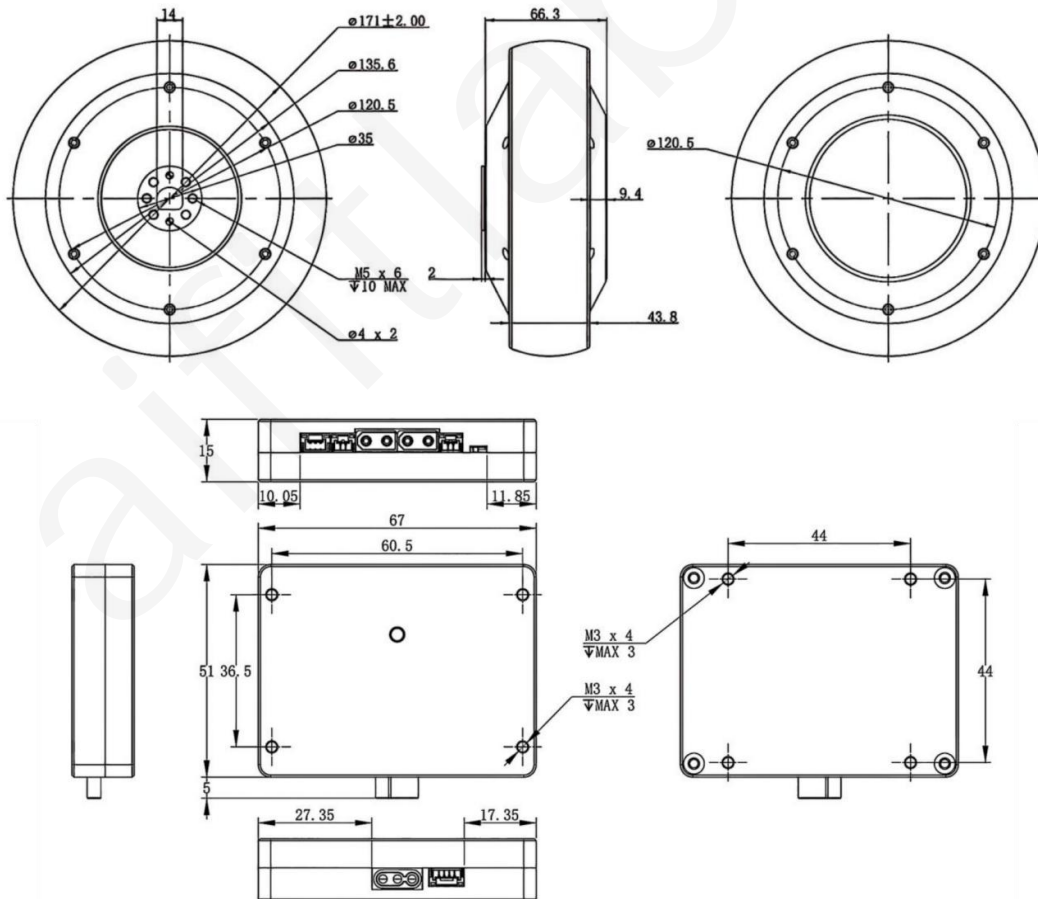

Indicator status

Normal Status	Green LED steady on.	The ERR bit is 1, indicating the enabled state.
	Red LED steady on.	The ERR bit is 0, indicating a disabled state.
Abnormal Status	Red LED flashing	<p>Indicates a fault, corresponding to the following fault type:</p> <ul style="list-style-type: none">5-Error in reading calibration data;6-read motor parameter error;7—abnormal sensor reading;8-over voltage;9—under voltage;A— excess current;B—MOS overheating;C-Motor coil overheating; E-Overload;D—communication loss; <p>You can check the specific fault through CAN data feedback frames or the DAMIAO Technology Debug Assistant interface.</p>

Operating Modes

MIT Mode

The MIT mode is designed to be compatible with the original MIT mode, enabling seamless switching while allowing flexible configuration of control parameters (P_MAX , V_MAX , T_MAX). The electronic controller converts received CAN data into control variables, calculates torque values, and sets them as current references for the current loop. The current loop then adjusts according to its regulation rules to ultimately achieve the specified torque current. The control block diagram is shown below:

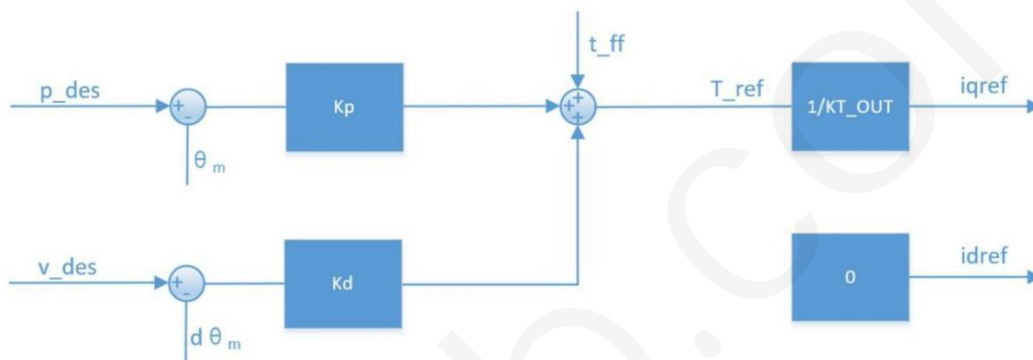

The MIT model can be adapted to various control configurations. For instance, when $k_p=0$ and $k_d \neq 0$, a constant-speed rotation can be achieved by setting v_des . Similarly, when $k_p=0$ and $k_d=0$, torque output can be controlled by setting t_ff .

Note: When controlling position, do not set k_d to 0, as this may cause motor oscillation or even loss of control.

Position-Speed Mode

The position-speed control mode employs a three-loop series control configuration. The outermost position loop provides the speed loop's setpoint, while the inner current loop receives the speed loop's output to regulate actual current. The schematic diagram of this control system is shown below.

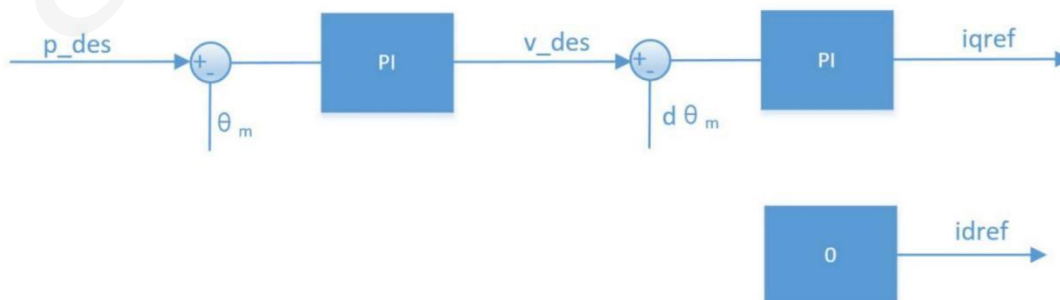

p_des is the target position for control, while v_des defines the maximum absolute speed during motion.

When the cascade mode is controlled using the parameters recommended by the debugging assistant, it achieves better control accuracy and a smoother process, though with longer response time. In addition to v_des , other configurable parameters include acceleration/deceleration settings. If additional oscillations occur during control, increasing acceleration/deceleration can mitigate them.

Note: The units of p_des and v_des are rad and rad/s, respectively, with the data type set to float. The damping factor must be set to a positive number other than 0. Refer to the speed mode notes.

Speed mode

The speed mode enables the motor to operate stably at the set speed, as shown in the control block diagram below.

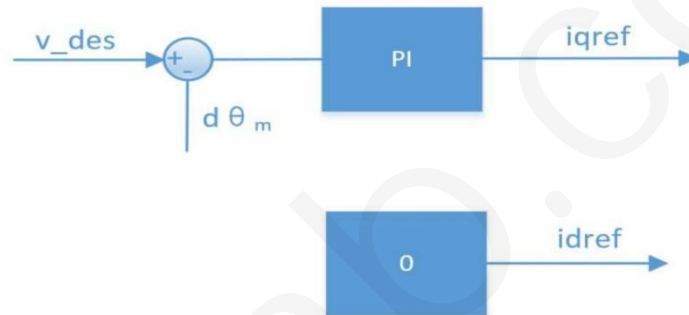

Note: v_des is measured in rad/s and is a float data type.

Hybrid mode of power and position control

The position-force hybrid control mode dynamically adjusts the output torque based on position-speed mode control, as shown in the control block diagram below:

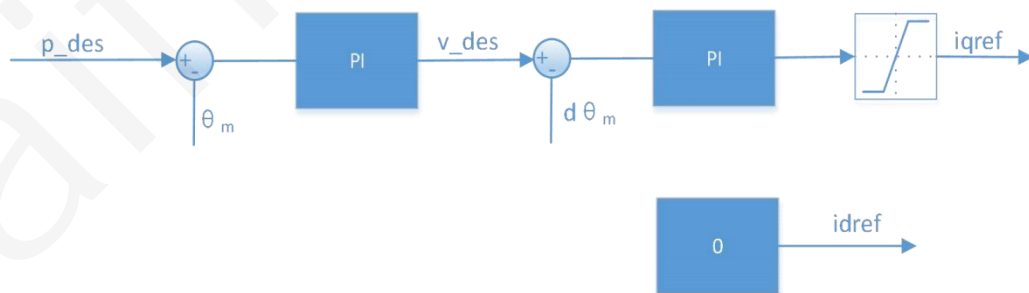

The current loop is limited to a given range by adding a current command saturation link after the output command of the speed loop.

Edit Mode

The mode can be configured via the host computer's serial port. Simply select the desired mode and click 'Write Parameters'. After successful setup, the motor will

automatically reset, with the mode stored in the motor driver for permanent preservation during power loss.

Additionally, modifications can be made via the CAN interface to update the mode register settings, as detailed in the 'Mode Switching' section of the next chapter. This configuration will prevent motor reset but will reset the following five variables to zero:

1. Location command value
2. Speed command value
3. Torque command value (MIT mode)
- 4.kp (MIT mode)
- 5.kd (MIT mode)

The mode will not be saved without sending the "Save Parameters" command. It will be lost after a power outage and restored upon power-up,Return to the last saved mode.

CAN Communication

After completing motor calibration, parameter setting, and configuration, the system becomes operational. It uses CAN standard frame (STD) format with a default baud rate of 1Mbps, though command-based switching to different baud rates is available (see next chapter for details). Functionally, frames are categorized into receiving frames and feedback frames. Receiving frames contain control data for motor command execution, while feedback frames transmit status data from the motor to the upper controller. The feedback mechanism operates on an inquiry basis: when the driver receives a frame ID matching the motor's configured CAN ID (with low 8 bits for parity check and high 3 bits ignored), it sends the current status data to the bus. Although receiving frame formats and IDs vary by motor mode, the feedback frames remain consistent across all operational modes.

Change baud rate

The baud rate can be configured via the host computer's serial port. Simply select the desired baud rate and click 'Write Parameters '. After successful setup, the motor will automatically reset, with the baud rate stored in the motor driver's internal memory to prevent data loss during power outages.

Another method involves modifying the baud rate via the CAN interface by writing the value into the baud rate register, as detailed in the 'CAN Baud Rate Modification' section of this chapter.

Note: Modifying the baud rate via CAN may fail if multiple devices are connected to the bus. Exercise caution and configure the baud rate before use.

Feedback frame

The feedback frame ID is set by the debug assistant (Master ID), with a default value of 0. It primarily provides feedback on the motor's position, speed, and torque. The frame format is defined as:

feedback message	D[0]	D[1]	D[2]	D[3]	D[4]	D[5]	D[6]	D[7]
MST_ID	ID ERR<<4	POS[15:8]	POS[7:0]	VEL[11:4]	VEL[3:0] T[11:8]	T[7:0]	T_MOS	T_Rotor

among :

ID indicates the controller's ID, with the lower 8 bits of CAN_ID (ERR) representing the status, corresponding to the following status types:

0-Disability;

1—Enable;

5-Error in reading calibration data;

6-Read motor parameter error;

7-Abnormal sensor reading;

8—overpressure;

9-Under-voltage;

A—— excess current;

B—MOS overtemperature;

C-Motor coil overheating;

D-Communication loss;

E—— overload ;

POS indicates the motor's position information

VEL indicates the motor speed information

T represents the torque information of the motor

T_MOS is the average temperature of the upper MOS, in °C

T_Rotor is the average temperature of the motor's internal coils, measured in °C

The system converts floating-point data to signed fixed-point data using linear mappings for position, speed, and torque. Specifically, position is represented by 16-bit data, while speed and torque are both 12-bit, as shown in the figure below.

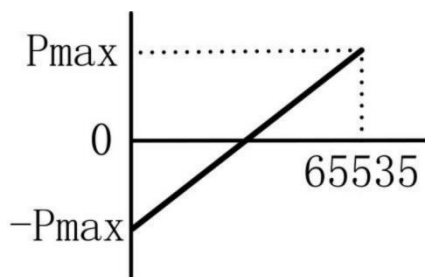

Figure: Position Linear Mapping

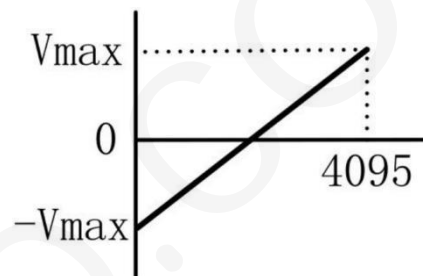

Figure: Speed Linear Mapping Diagram

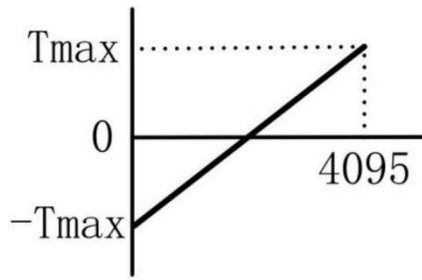

Figure: Torque Linear Mapping Diagram

Note:

- ① After power-on, the motor position output is limited to $[-\pi, \pi]$ radians.
- ② The unit of position is rad (radian), and all subsequent descriptions of position shall follow this definition without further elaboration.
- ③ The unit of velocity is rad/s (radians per second). All subsequent descriptions of velocity shall follow this definition, and no further elaboration is required.
- ④ Torque is measured in Nm, and all subsequent descriptions of torque will follow this definition without further elaboration.

Control frame in MIT mode

control message	D[0]	D[1]	D[2]	D[3]	D[4]	D[5]	D[6]	D[7]
ID	p_des [15:8]	p_des [7:0]	v_des [11:4]	v_des[3:0] Kp[11:8]	Kp [7:0]	Kd [11:4]	Kd[3:0] t_ff[11:8]	t_ff[7:0]

The frame ID equals the set CAN ID value.

p_des: Position given

v_des: speed given

Kp: Position Ratio Coefficient

Kd: Positional differential coefficient

t_ff: Torque setpoint

All parameters adhere to the mapping relationships specified in the previous section. The values of p_des, v_des, and t_ff can be configured via the debugging assistant, while Kp ranges from 0 to 500 and Kd ranges from 0 to 5.

A standard CAN data frame is 8 bytes long. MIT's control command format encodes five parameters—Position, Velocity, Kp, Kd, and Torque—into 8 bytes using bit combinations. Specifically: Position occupies 2 bytes (16 bits), Velocity 12 bits, Kp 12 bits, and Kd 12 bits.

The MIT command converts floating-point data to integers proportionally and sends them to the driver, which then converts the received integers back to floating-point data proportionally. This conversion is handled by two functions, uint_to_float and float_to_uint, as detailed below:

```
1. float uint_to_float(int x_int, float x_min, float x_max, int bits){  
2. // converts unsigned int to float, given range and number of bits ///  
3. float span = x_max - x_min;  
4. float offset = x_min;  
5. return ((float)x_int)*span/((float)((1<<bits)-1)) + offset;  
6. }.
```

```
1. int float_to_uint(float x, float x_min, float x_max, int bits){  
2. // Converts a float to an unsigned int, given range and number of bits ///  
3. float span = x_max - x_min;  
4. float offset = x_min;  
5. return (int) ((x-offset)*((float)((1<<bits)-1))/span);  
6. }.
```

To apply these two conversion functions, first determine the maximum and minimum values for proportional scaling. These parameters can be found on the parameter settings page, where KP and KD default to 0.0 – 500.0 and 0.0 – 5.0 respectively. Pos, Vel, and Torque are set to ± 12.566 , ± 100 , and ± 40 by default, though these values can be adjusted according to the motor's actual parameters. When sending control commands, ensure they match the set values to prevent proportional scaling.

Control frame in position velocity mode

control message	D[0]	D[1]	D[2]	D[3]	D[4]	D[5]	D[6]	D[7]
0x100+ID	p_des				v_des			

The frame ID is the set CAN ID value plus an offset of 0x100.

p_des: Position given, floating-point type, with the lower bit first and the higher bit last

v_des: speed given, floating-point, lower bits first, higher bits last

The CAN ID for the command is 0x100+ID. The speed setting is the maximum speed value during operation.

Control frame in speed mode

control message	D[0]	D[1]	D[2]	D[3]
0x200+ID	v_des			

The frame ID is the set CAN ID value plus an offset of 0x200.

v_des: A floating-point variable with fixed speed, where the lower bit is first and the higher bit is last. The CAN ID for this command is 0x200+ID.

Control frame in position and force hybrid control mode

control message	D[0]	D[1]	D[2]	D[3]	D[4]	D[5]	D[6]	D[7]
0x300+ID	p_des			v_des			i_des	

p_des: A floating-point type with a fixed position, measured in radians, where the least significant bit is first and the most significant bit is last.

Save position zero

The "Save Position Zero Point" frame is a control frame that resets the current output axis to zero position and sets the position value to 0. As mentioned earlier, the frame ID and data segment definition are as follows:

D[0]	D[1]	D[2]	D[3]	D[4]	D[5]	D[6]	D[7]
0xFF	0xFF	0xFF	0xFF	0xFF	0xFF	0xFF	0xFE

Clear errors

When the motor experiences overheating or other faults, the 'Clear' command can be sent to resolve the issue. The 'Clear' frame is a control frame, with the frame ID as previously described and the data segment defined as follows:

D[0]	D[1]	D[2]	D[3]	D[4]	D[5]	D[6]	D[7]
0xFF	0xFF	0xFF	0xFF	0xFF	0xFF	0xFF	0xFB

Read parameters

message ID	attribute	D[0]	D[1]	D[2]	D[3]
0x7FF	STD	CANID_L	CANID_H	0x33	RID

RID is the register address, see Appendix <Register List and Range>

After successful read, the data of the register is returned, with the frame format as follows:

message ID	attribute	D[0]	D[1]	D[2]	D[3]	D[4]	D[5]	D[6]	D[7]
MST_ID	STD	CANID_L	CANID_H	0x33	RID	data			

The data is either floating-point or unsigned integer, occupying 32 bits (4 bytes), with D4 as the least significant bit and D7 as the most significant bit, and so on.

In parameter

message ID	attribute	D[0]	D[1]	D[2]	D[3]	D[4]	D[5]	D[6]	D[7]
0x7FF	STD	CANID_L	CANID_H	0x55	RID	data			

As described above, the RID returns the written data upon successful completion, with the frame format identical to the original sent data.

message ID	attribute	D[0]	D[1]	D[2]	D[3]	D[4]	D[5]	D[6]	D[7]
MST_ID	STD	CANID_L	CANID_H	0x55	RID	data			

Writing register data takes effect immediately but cannot be stored. The data is lost after power failure. A command to send storage parameters is required to write all modified parameters into the chip.

Storage parameters

message ID	attribute	D[0]	D[1]	D[2]	D[3]
0x7FF	STD	CANID_L	CANID_H	0xAA	0x01

After successful write, the return format is:

message ID	attribute	D[0]	D[1]	D[2]	D[3]
MST_ID	STD	CANID_L	CANID_H	0xAA	0x01

Note:

The storage parameters are only effective in the disabled mode.

- ② All parameters will be stored in one go.
- ③ This operation writes parameters to the on-chip flash memory, with each operation lasting up to 30ms. Ensure you allow sufficient time.
- ④ The flash memory can withstand approximately 10,000 erase cycles. Avoid frequent transmission of the "storage parameters" command.

✧ Mode switch

Supports switching between multiple modes. The supported control modes are:

Code	Mode
1	MIT
2	velocity of position
3	velocity
4	Hybrid control of position and force

By adjusting the mode register (0x0A), the operating mode can be modified. During mode switching, the motor first resets all command values, including position, speed, and the torque feedforward and KP/KD parameters in MIT mode.

To prevent shock during mode switching from position control to another mode, it is recommended to first read the precise position (value of register 0x50) before considering the switch, and to perform the switch when the motor is at zero speed.

After modifying the mode, it won't be saved to the flash memory and will be lost when the power is cut. Upon reboot, the control mode will revert to the last saved configuration in the flash.

CAN baud rate modification

The current CAN communication baud rate can be modified by writing specific data to the baud rate register (address 0x23), supporting customized baud rate settings. The supported baud rates are as follows:

Code	Baud rate
0	125K
1	200K
2	250K
3	500K
4	1M
5	2M
6	2.5M
7	3.2M
8	4M
9	5M

After the baud rate is successfully modified, the driver first feeds back data at the original baud rate, then communicates at the new baud rate. Power on the motor first checks the stored baud rate. If it exceeds 5Mbps, the system automatically defaults to 1Mbps. For baud rates above 1Mbps (excluding 1Mbps), the motor switches to CAN FD mode. When the baud rate is 1Mbps or lower, it switches to CAN 2.0B. Motors configured as CAN FD can still receive 1Mbps data frames but use CAN FD for feedback transmission, causing the upper controller to miss feedback data and the driver to repeatedly report errors. Controllers using CAN 2.0B can revert to the original baud rate by issuing a baud rate adjustment command.

Note: Modifying the baud rate via CAN may fail if multiple devices are connected to the bus. Exercise caution and configure the baud rate before installation.

Register list and range

Address (HEX)	Address (DEC)	Variable	Description	Read-write	Scope	Type
0x00	0	UV_Value	Low voltage protection value	RW	(10.0, fmax]	float
0x01	1	KT_Value	Torque coefficient	RW	[0.0, fmax]	float
0x02	2	OT_Value	Over temperature protection value	RW	[80.0, 200)	float
0x03	3	OC_Value	Overcurrent protection value	RW	(0.0, 1.0)	float
0x04	4	ACC	Accelerated speed	RW	(0.0, fmax]	float
0x05	5	DEC	Deceleration	RW	[-fmax, 0.0)	float
0x06	6	MAX_SPD	Maximum speed	RW	(0.0, fmax]	float
0x07	7	MST_ID	Feedback ID	RW	[0, 0xFF]	uint32
0x08	8	ESC_ID	Receive ID	RW	[0, 0xFF]	uint32
0x09	9	TIMEOUT	Timeout alert time	RW	[0, 2 ³² -1]	uint32
0x0A	10	CTRL_MODE	Control model	RW	[0, 4]	uint32
0x0B	11	Damp	Motor viscosity coefficient	RO	/	float
0x0C	12	Inertia	Rotating inertia of motor	RO	/	float
0x0D	13	hw_ver	Continue to have	RO	/	uint32
0x0E	14	sw_ver	Software version	RO	/	uint32
0x0F	15	SN	Continue to have	RO	/	uint32
0x10	16	NPP	Number of pole pairs of motor	RO	/	uint32
0x11	17	Rs	Motor phase resistance	RO	/	float
0x12	18	Ls	Motor phase inductance	RO	/	float
0x13	19	Flux	Motor flux linkage	RO	/	float
0x14	20	Gr	Gear reduction ratio	RO	/	float
0x15	21	PMAX	Position mapping range	RW	(0.0, fmax]	float
0x16	22	VMAX	Velocity mapping range	RW	(0.0, fmax]	float
0x17	23	TMAX	Torque mapping range	RW	(0.0, fmax]	float
0x18	24	I_BW	Current loop control bandwidth	RW	[100.0, 1.0e4]	float

Address (HEX)	Address (DEC)	Variable	Description	Read-write	Scope	Type
0x19	25	KP_ASR	Speed ring Kp	RW	[0.0,fmax]	float
0x1A	26	KI_ASR	Speed ring Ki	RW	[0.0,fmax]	float
0x1B	27	KP_APR	Position loop Kp	RW	[0.0,fmax]	float
0x1C	28	KI_APR	Position loop Ki	RW	[0.0,fmax]	float
0x1D	29	OV_Value	Overvoltage protection value	RW	TBD	float
0x1E	30	GREF	Gear torque efficiency	RW	(0.0, 1.0]	float
0x1F	31	Deta	Speed loop damping coefficient	RW	[1.0,30.0]	float
0x20	32	V_BW	Speed loop filter bandwidth	RW	(0.0,500.0)	float
0x21	33	IQ_c1	Current loop enhancement factor	RW	[100.0, 1.0e4]	float
0x22	34	VL_c1	Speed loop enhancement coefficient	RW	(0.0, 1.0e4]	float
0x23	35	can_br	CAN baud rate code	RW	[0,4]	uint32
0x24	36	sub_ver	Subversion number	RO	/	uint32
0x25	37	Boot_ver	Boot version number	RO	/	uint32
0x37	55	dir	Direction	RO	/	float
0x38	56	m_off	Motor side angular offset	RO	/	float
0x3B	59	lmax	Maximum current of drive board	RO	/	float
0x3C	60	VBus	Supply voltage	RO	/	float
0x3D	61	Tpcb	Drive board temperature	RO	/	float
0x3E	62	Tmtr	Motor temperature	RO	/	float
0x3F	63	Iu_off	U-phase current bias	RO	/	float
0x40	64	Iv_off	V-phase current bias	RO	/	float
0x41	65	Iw_off	W-phase current bias	RO	/	float
0x50	80	p_m	Motor current position	RO	/	float

RW: Read-write.

RO: read only.

Motor commissioning process

Use a host computer version V2.0.0.0 or later for debugging. The following demonstrates the debugging process with V2.0.3.4.

Interface

First, connect the motor's serial port, CAN port, and power interface. On the computer, open the Debug Assistant software, select the corresponding serial port device, and enable the serial port.



When power is supplied to the motor, the serial port will display the following information. Control Mode: indicates the current drive mode. Different modes use different command formats (refer to the CAN Communication section).

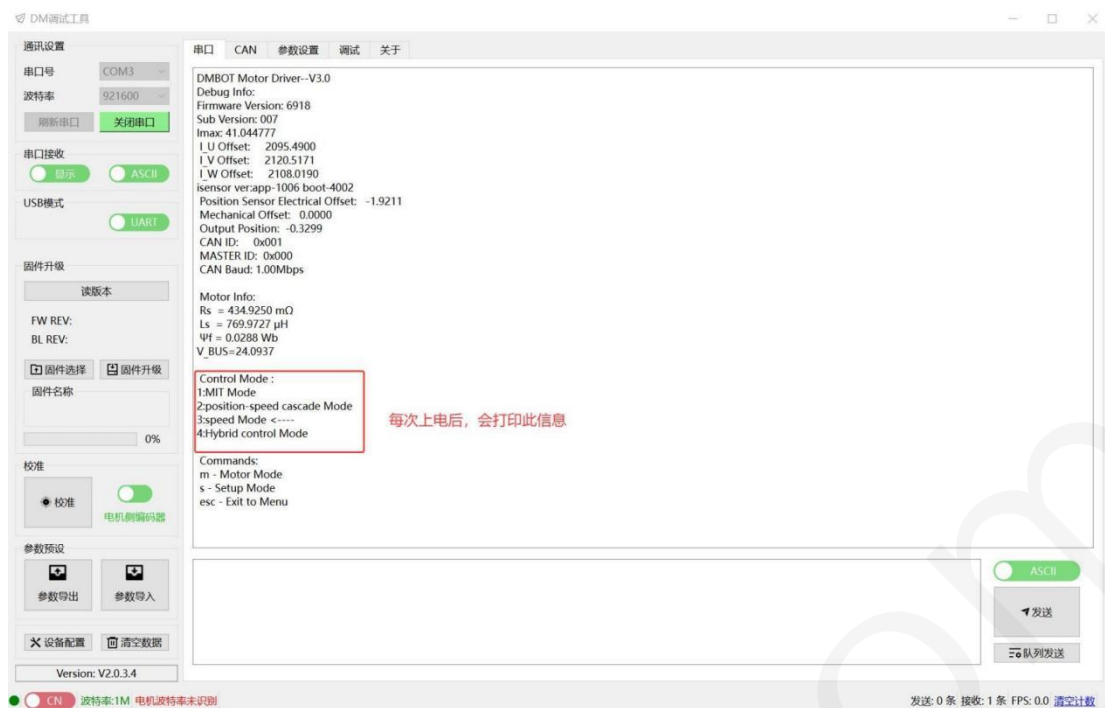

Encoder calibration

The primary purpose of encoder calibration is to correct sensor installation errors. During calibration, the motor rotates one rotor cycle in both directions. Ensure the motor rotates freely and operates under no-load conditions to prevent calibration failure. The motor has undergone factory calibration and stored the calibration data internally. After replacing the driver board, the information remains intact. In normal circumstances, the motor can be used directly without additional calibration. Below are the calibration steps. For abnormal conditions such as excessive vibration, perform calibration before operation.

Step 1: Select the calibration item select 'Motor-side Encoder', click Calibrate. The motor will rotate first, then return the pole pairs to the debugging assistant after rotation.

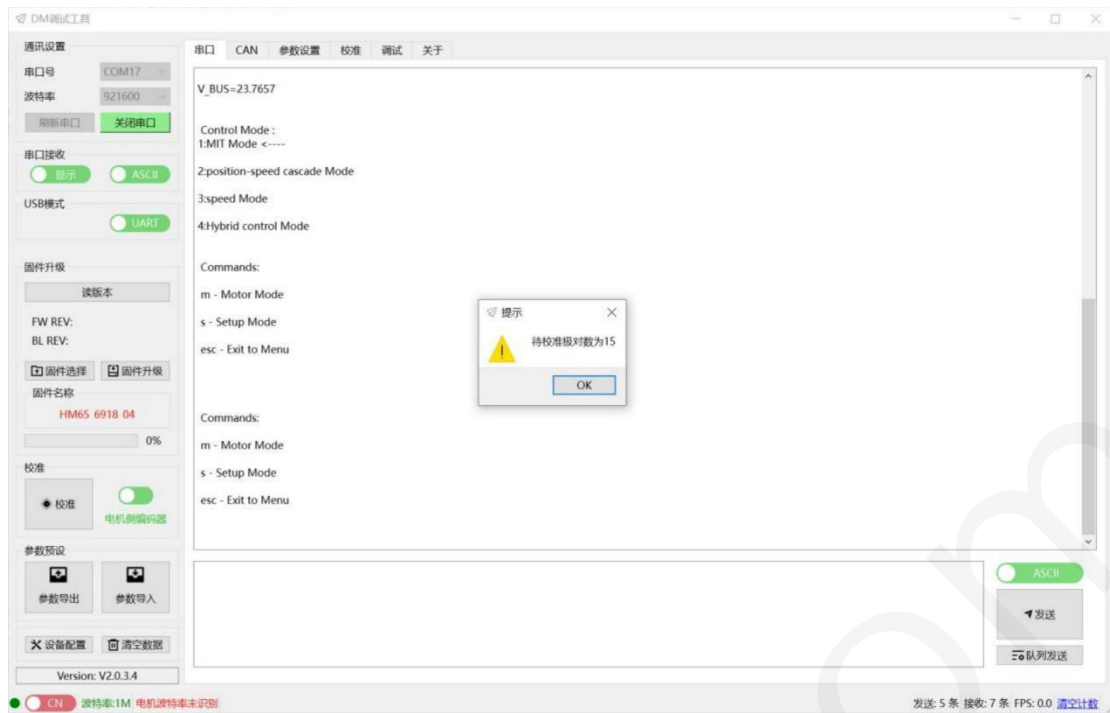

The motor will first rotate forward once, then backward once. Ensure the motor is securely fastened to prevent accidents. During calibration, the system displays the operational curve as shown below: the red line represents the reference angle, the blue line shows the motor's measured angle, and the green line indicates the error between the two.

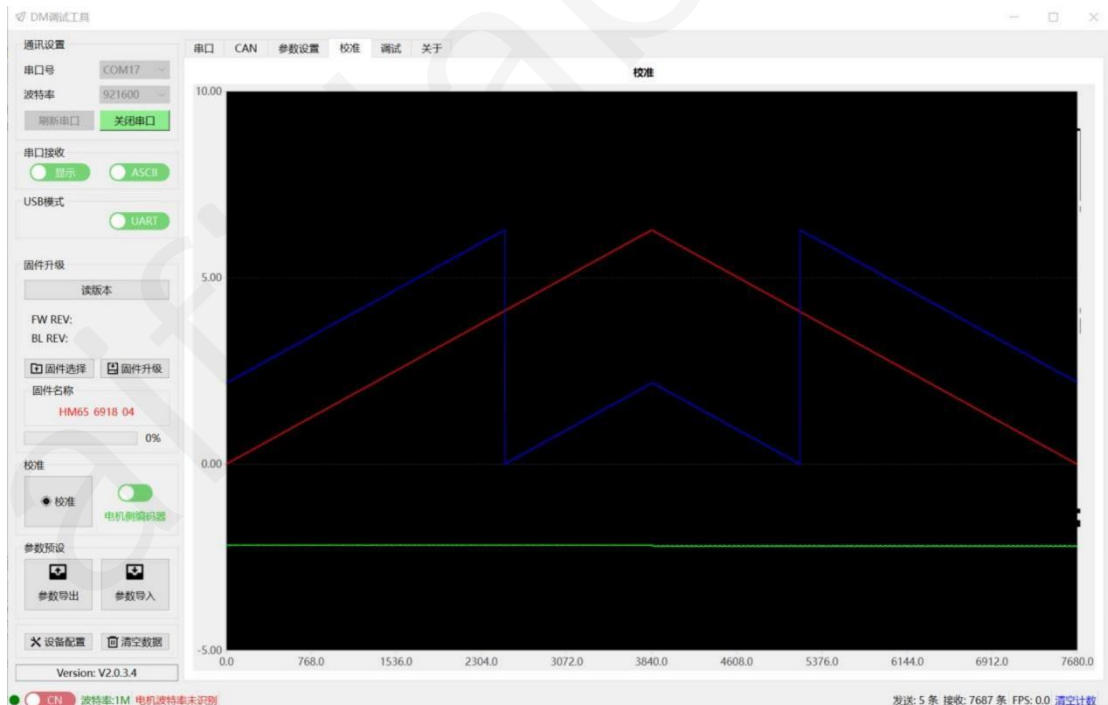

Step 2: After calibration is completed, the host computer processes the calibration data and immediately sends it to the driver, which then receives it. Afterward, the host computer will display 'Transmission Successful' as shown below:

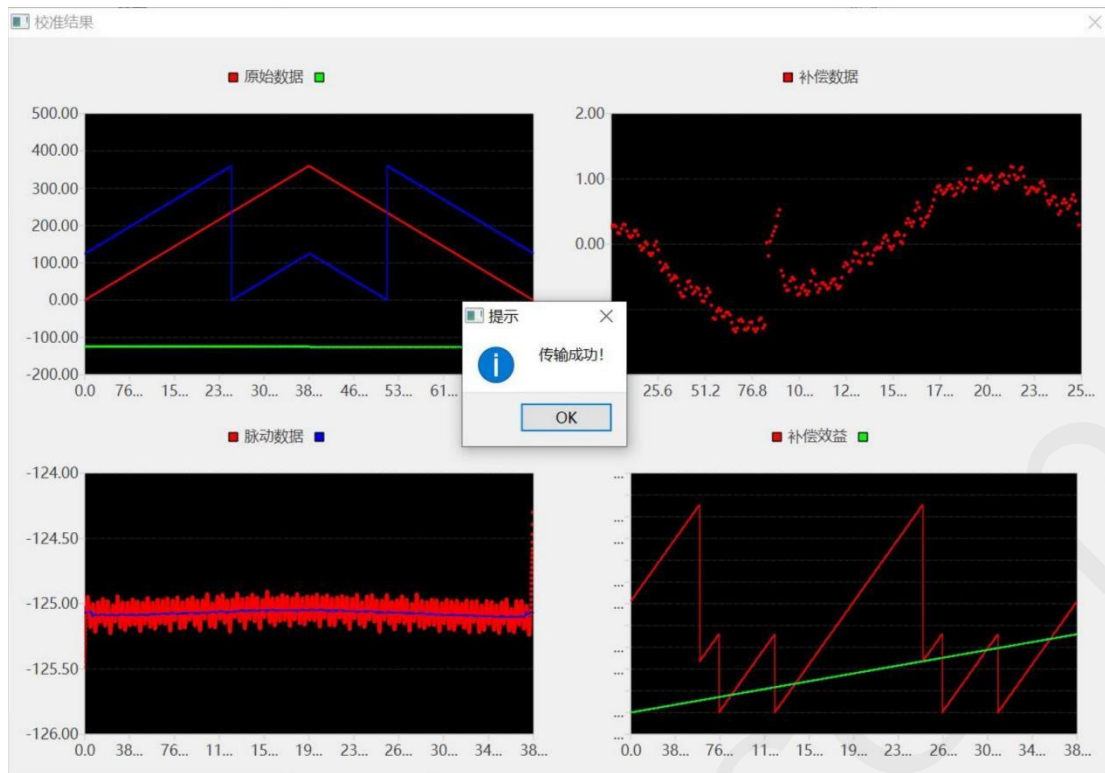

Parameter calibration

Parameter identification primarily determines critical motor parameters including phase resistance, phase inductance, and magnetic flux. These parameters are factory-calibrated and embedded in the motor. After replacing the driver board, the information remains intact, allowing direct operation without recalibration. Below are the calibration procedures:

Click the "Parameter Settings" tab, then click the "Parameter Calibration" button to initiate the driver's identification process. During this time, the motor will rotate; ensure it remains unloaded and securely fastened.

电机参数

相电阻 (R) :	420.812 mR	参数标定
相电感 (L) :	758.658 uH	
磁链 (λ) :	0.024964 Wb	
粘滞系数:	0.014032	
转动惯量:	0.00168217 kg*m ²	

After recognition, the results will be uploaded automatically. The viscosity coefficient is only for reference and can be calibrated many times.

[Note] All parameters except the viscosity coefficient must be positive. If negative values occur, verify the motor status before recalibration.

Serial port read/write parameters

1. Read parameters

Under the Parameters tab, click the Read Parameters button. The driver will upload the parameters used for storage to the Debug Assistant. Check the parameters carefully.

The screenshot shows the 'DM Test Tool' software interface. The 'Parameters' tab is active, displaying various motor and driver parameters. A red circle '1' highlights the 'Parameters' tab, and another red circle '2' highlights the 'Read Parameters' button. The interface includes sections for 'Motor Parameters', 'Drive Parameters', 'Communication Parameters', and 'Control Parameters'. A control diagram at the bottom shows a feedback loop for velocity control (v_{des}) using a PI controller and a feedforward term ($d\theta_m$) to generate a reference current (i_{qref}).

电机参数 (Motor Parameters):

- 相电阻 (R): 422.974 mR
- 相电感 (L): 766.934 uH
- 磁链 (λ): 0.0249246 Wb
- 粘滞系数: 0.0131473
- 转动惯量: 0.00187379 kg*m²

驱动参数 (Drive Parameters):

- 极对数: 15
- 减速比: 1
- KI_current: 2500
- KI_speed: 250
- 加速度: 0.05
- 减速度: -0.05
- 限速: 1200
- fbw: 40
- 过流: 0.8
- 过温: 100
- 过压: 60
- 欠压: 10

通讯参数 (Communication Parameters):

- CAN ID: 0x01
- Master ID: 0x00
- CAN Timeout: 0
- CAN Baud: 1M
- 子版本号: 7

控制参数 (Control Parameters):

- PMAX: 3.14159
- VMAX: 100
- TMAX: 40
- KT_OUT: 0
- 齿轮系数: 1
- 阻尼因子: 4
- 控制模式: 3速度模式
- 电流带宽: 1000
- 速度 KP: 0.53
- 速度 KI: 0.002
- 位置 KP: 54
- 位置 KI: 0

反饋报文 (Feedback Messages):

反饋报文	D0[7:4]	D0[3:0]	D1	D2	D3	D4[7:4]	D4[3:0]	D5	D6	D7
MST_ID	ERR	ID	POS[15:8]	POS[7:0]	VEL[11:4]	VEL[3:0]	T[11:8]	T[7:0]	T_MOS	T_Rotor

控制报文 (Control Messages):

控制报文	D0	D1	D2	D3
0x200+ID	v_des			

Legend:

- ID 表示控制器的ID, 取CAN ID的低8位
- ERR 表示状态, 对应状态类型为: 0—失败; 1—使能; 8—超速; 9—欠压; A—过电流; B—MOS过温; C—电机线圈过温; D—通讯丢失; E—过载;
- POS 表示电机的位置信息, 单位rad
- VEL 表示电机的速度信息, 单位rad/s
- T 表示电机的扭矩信息, 单位N·m
- T_MOS 表示驱动上MOS的平均温度, 单位°C
- T_Rotor 表示电机内部线圈的平均温度, 单位°C
- 位置、速度和扭矩采用线性映射的关系将浮点型数据转换成有符号的定点数据, 其中位置采用16位数据, 速度和扭矩均使用12位。



The read parameters include:

(1) Drive Parameters: The parameter settings section for driving

Pole pairs: The number of pole pairs in the motor, which can be automatically determined through calibration. Do not modify it.

Under-voltage: If the power supply voltage falls below the set threshold (default: 20V), the driver will fail to control the motor operation.

Overvoltage: Sets the maximum operating voltage for the driver. When the motor is powered on, the system measures the supply voltage. If the measured voltage exceeds this threshold, the driver triggers an error and deactivates. If overvoltage occurs during startup, the driver will continue to display errors.

Acceleration/deceleration: Used in non-MIT mode to limit the drive's acceleration/deceleration and motor rotor parameters, measured in Krad/s^2 , where deceleration is negative.

Reduction ratio: The motor's reduction ratio is fixed at 1. Do not modify it.

Overtemperature: The motor coil's temperature protection threshold is configurable based on operational requirements, with a recommended maximum of

100°C. When exceeded, the driver will deactivate, enter an inoperative state, and trigger an error.

CAN_ID: The driver ID number used for CAN commands, expressed in hexadecimal. It is recommended to set it to a value less than 16 to avoid conflicts with error types.

Master ID: The frame ID used by the driver for feedback information, in hexadecimal format;

CAN Timeout: A 32-bit integer setting that defines the time threshold after which no CAN command is detected, triggering motor protection. Each count cycle lasts 50 microseconds and is only active when the motor is enabled.

I Speed limit: Used exclusively in speed mode to restrict the maximum operating speed of the motor rotor, measured in rad/s.

I Overcurrent: A percentage value that limits the maximum phase current of the motor;

CAN baud rate: Configurable CAN baud rate, supports 125Kbps to 5Mbps;

ki_current (current loop enhancement coefficient): an auxiliary control parameter for the current loop, which should not be modified.

fbw (speed loop filter bandwidth): rotational speed filter bandwidth, measured in Hz;

Subversion number: the firmware subversion number;

k_i speed (speed loop enhancement coefficient): A speed loop auxiliary control parameter, with a recommended adjustable range of 200-800.

Note: After successfully clicking to read parameters, the debugging interface parameters (e.g., PMAX, ID, etc.) will be updated automatically.

(2) Motor Parameters: Section on Motor Parameters

These parameters are automatically detected by the driver (no calibration required when replacing the driver board, as they are stored in the motor).

(3) Control amplitude: Set the parameter range of the drive command

P_{MAX}: In MIT mode, it is the mapped value for receiving motor commands, while in other modes, it serves as the mapped value for motor feedback. For mapping rules, refer to the CAN communication section.

V_{MAX}: Same as P_{MAX};

T_{MAX}: Same as P_{MAX};

K_{T_OUT}: The torque coefficient of the motor, set to 0 when the motor parameters are accurately identified.

Gear coefficient: the torque transmission coefficient of gears, less than or equal to 1.0;

Damping factor: the bandwidth ratio between current loop and speed loop control, not utilized.

(4) Control Settings

I Control modes: MIT mode, position velocity mode, velocity mode, force position hybrid mode;

I Current bandwidth: Set the gain coefficient of the current loop, default is 1000;

I Velocity K_P/K_I, Position K_P/K_I: parameters of the velocity loop and position loop;

After completing the parameter configuration, read and update the parameters to the host computer to ensure accurate feedback data.

2. Write parameters

Check the drive parameters, control amplitude, and control settings. Modify the parameters as needed, then click 'Write Parameters' to save the changes to the drive.

Clicking the 'Write Parameters' button will reset the chip automatically. To prevent safety hazards, ensure the motor is in the 'Disengaged' state when using this function.



Note:

Do not modify the parameters of the logarithmic pole and the speed reduction ratio.

Click 'Write Parameters' to automatically restart the driver without external power.

After completing the parameter writing, read and update the parameters to the host computer to ensure accurate feedback data.

Shakedown test

This function is available only when a CAN interface is connected. It can debug a single motor only. Connect the CAN cable to the driver board before operation. Before debugging, confirm the wiring sequence and current control mode, then select the appropriate sub-tab in the debugging page based on the mode.

1. Selection and Confirmation of Control Modes

In the debug assistant, go to 'Parameter Settings' and select 'Control Mode' from the control settings. You can choose from four modes: MIT mode, speed-position mode, speed mode, or force-position hybrid control. Then click 'Write Parameters' to finalize the control mode.



When you change the control mode, a prompt window will appear: "Write parameters successfully!"

The "Write parameters" feature resets automatically and does not require re-powering the drive to take effect. For earlier versions, after modifying the "Motor mode," you must re-power the drive for the parameters to take effect. The reminder has been turned off.



(1) The control mode is determined by analyzing the serial port print data from the upper power supply; the mode indicated by the arrow represents the current active control mode.



(2) Alternatively, the drive's control mode can be determined by checking the displayed information after re-reading parameters on the parameter setting page.



2. MIT mode

(1) Select and confirm the reference control mode. Set the current mode to MIT, then choose the corresponding MIT sub-tab in the debugging interface.

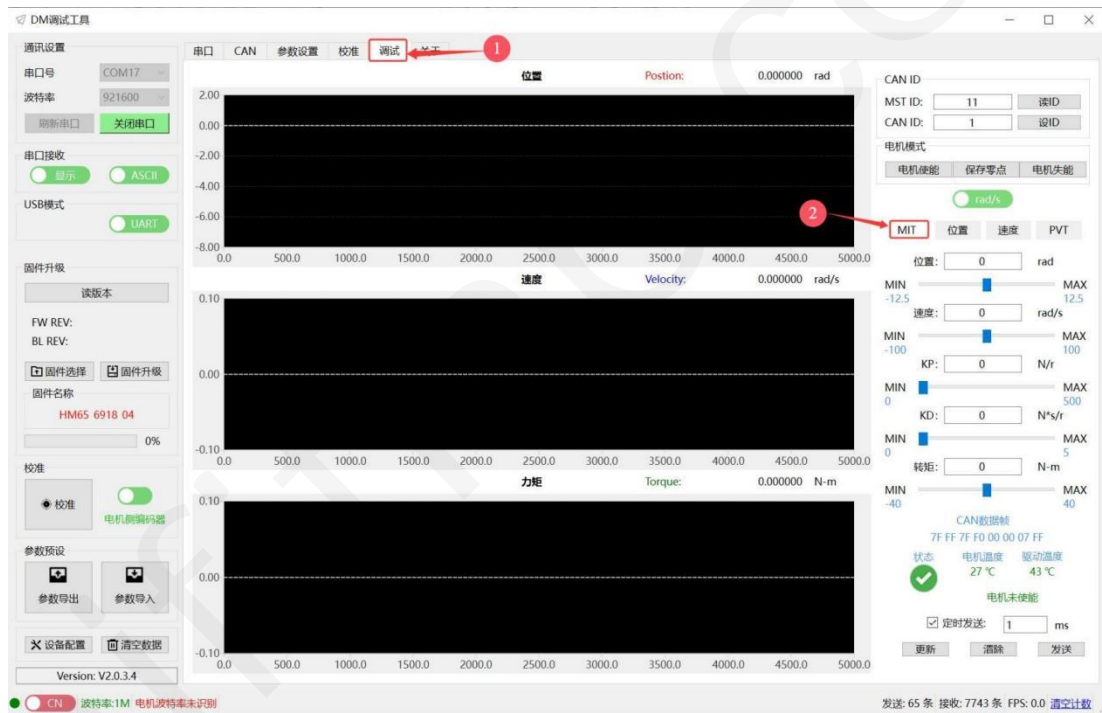

(2) Verify the CAN ID is correct (available through serial port printing, parameter settings, or debugging interface settings).



(3) The MIT mode features three control methods: speed, position, and torque.

① speed control

Step 1: Click the Enable button in the motor mode bar. The driver's green light will turn on, indicating the motor is enabled.



Step 2: Set the motor to operate at the specified speed.

For example: Set the speed to 5 rad/s, KD to 1 N-s/r, and all other parameters to 0. Check the 'Scheduled Send' box, then click 'Update' and 'Send' buttons in sequence. The parameter curve changes can be viewed in the debugging interface. Note: Keep the motor stationary.

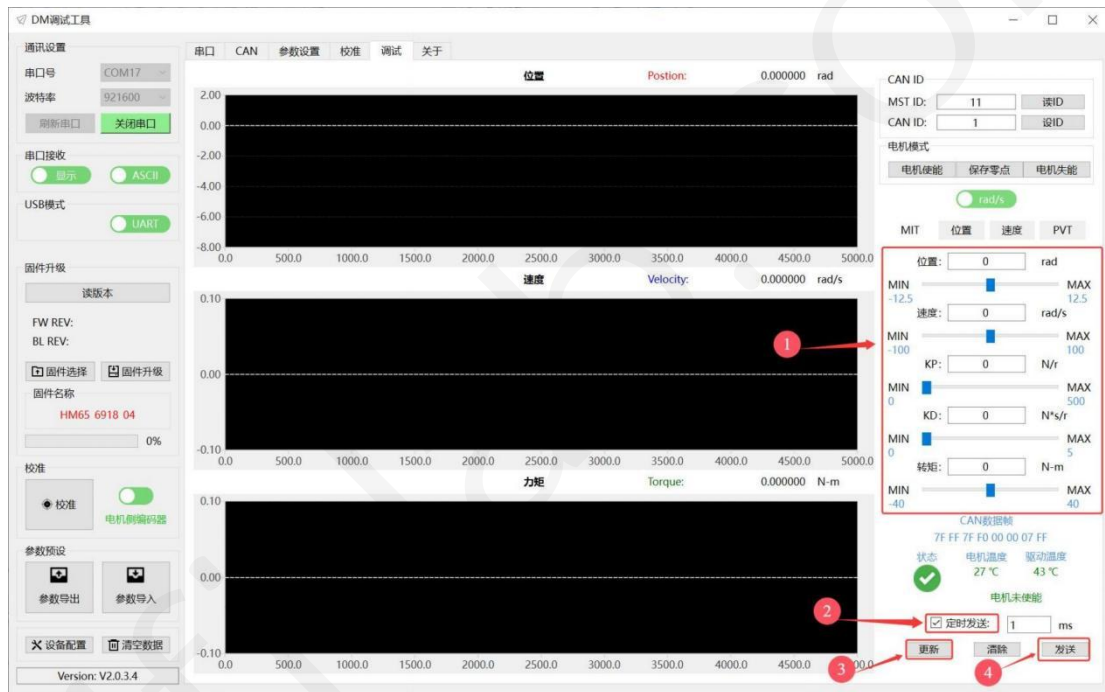

To debug, modify the control parameters and monitor changes. Edit parameters directly in the original interface, keep the 'Scheduled Send' option checked, then click 'Update' to proceed.

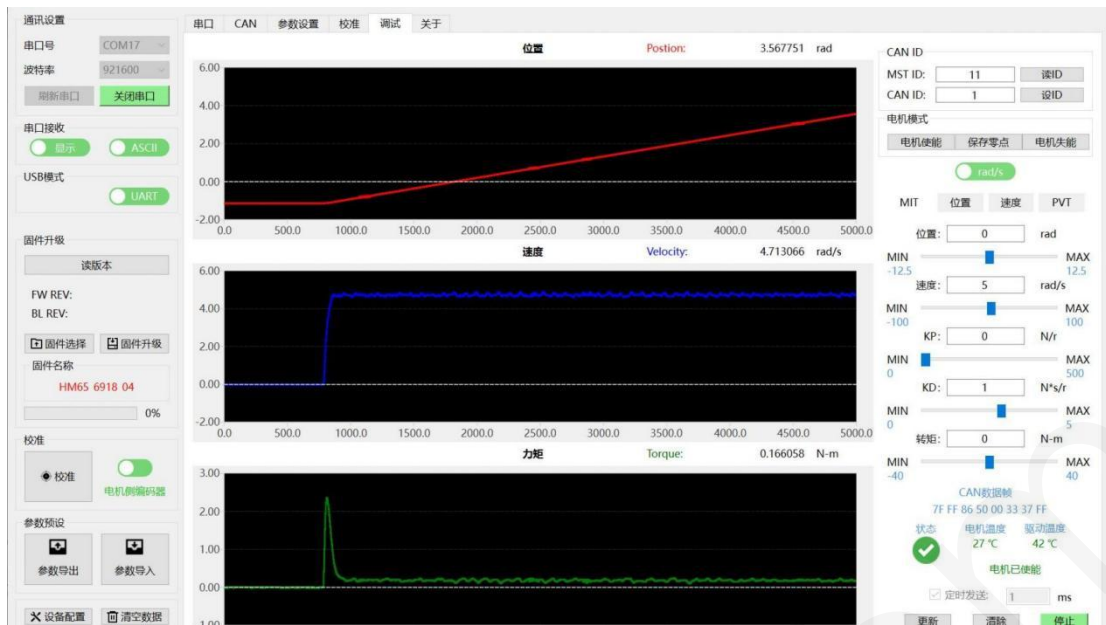

The debugging assistant interface displays real-time temperature data and operational status of the motor and drive. The feedback frame can also be viewed for details. For the format and types of feedback frames, please refer to the '4.1 Feedback Frame' section.

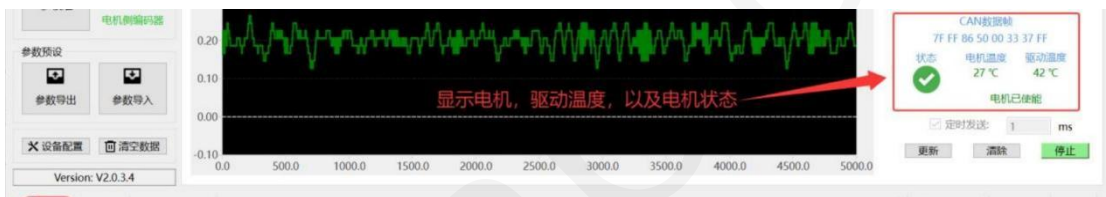

Step 3: To exit debug mode, click the "Stop" and "Disable" buttons in sequence. The red light on the drive will turn on, indicating the motor mode has been exited.

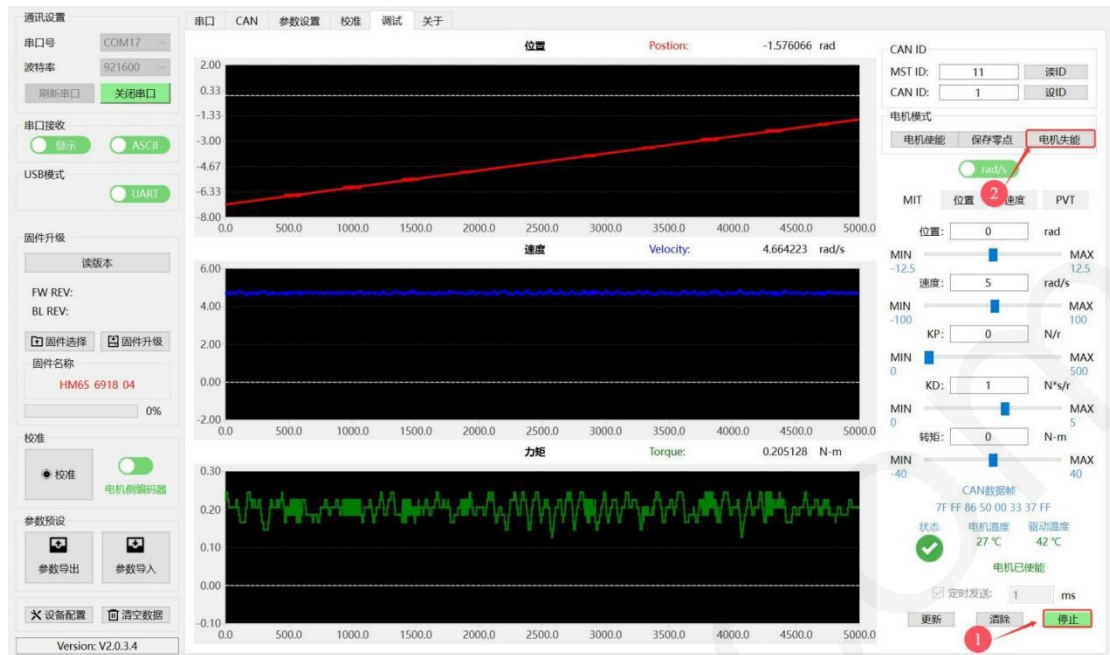

② position control

Step 1: Click the Enable button in the motor mode bar. The driver's green light will turn on, indicating the motor is enabled.

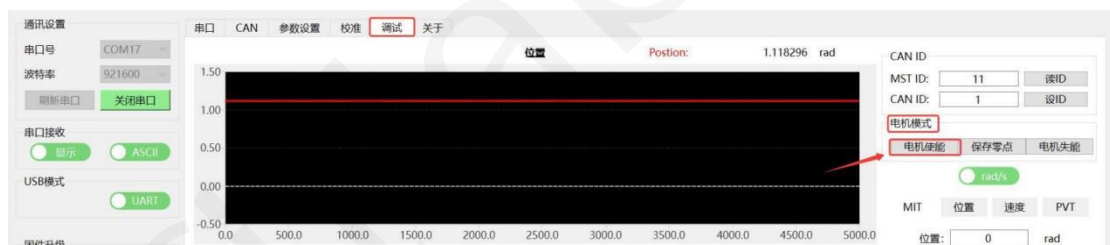

Step 2: Rotate the motor to the specified position.

When setting the 'position' parameter in the control parameters, ensure it closely matches the motor's initial position to prevent excessive deviation that could cause motor shock.

To set the motor's current position as zero, click 'Save Zero Point' in the command bar for easy position parameter configuration.

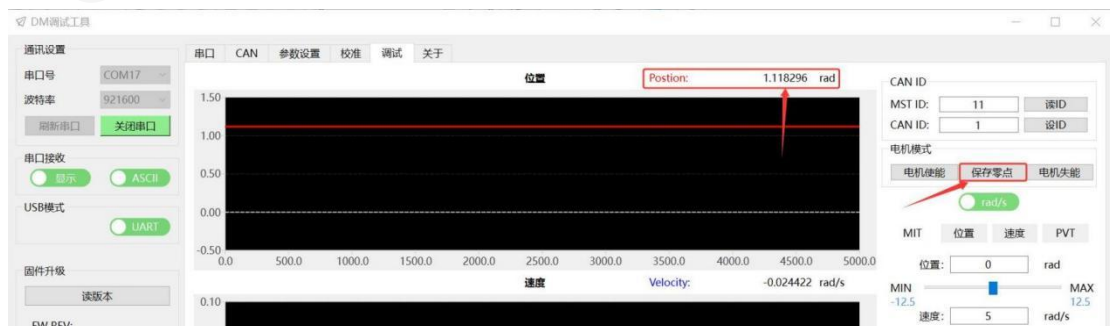

For example, with the following parameters: position set at 3.14 rad, KP set at 2N/r, KD set at 1N-s/r, and all other parameters set to 0, and with the 'Scheduled Send' box checked, click the 'Update' button followed by the 'Send' button in sequence. The parameter curve changes can be viewed in the debugging interface. Note: Keep the motor stationary.

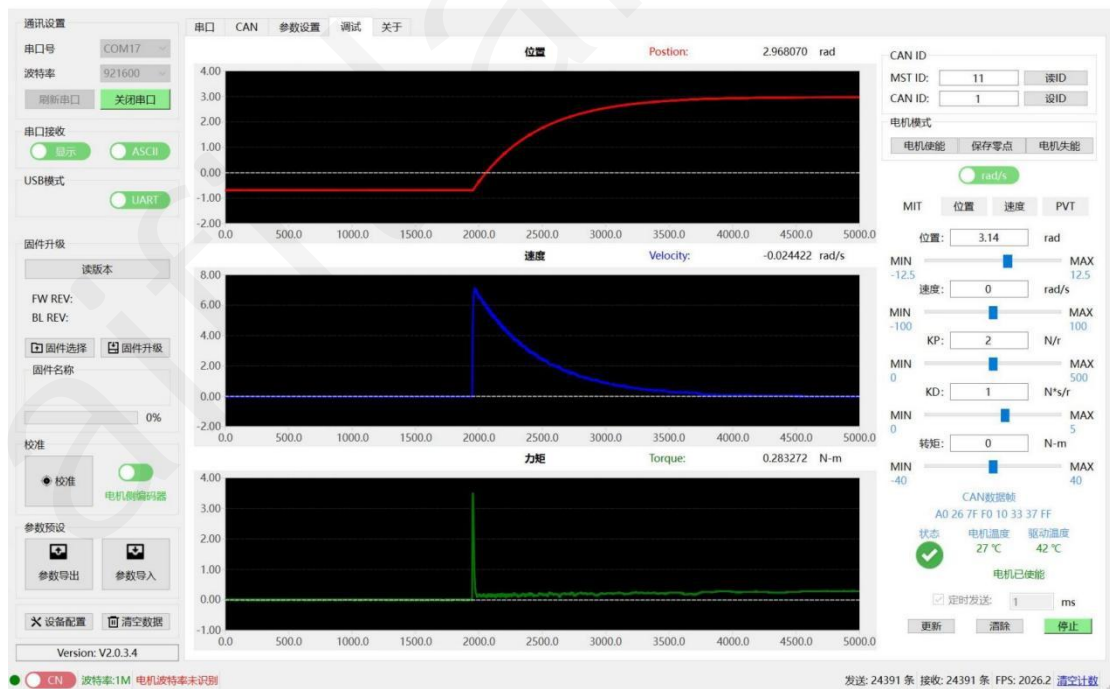
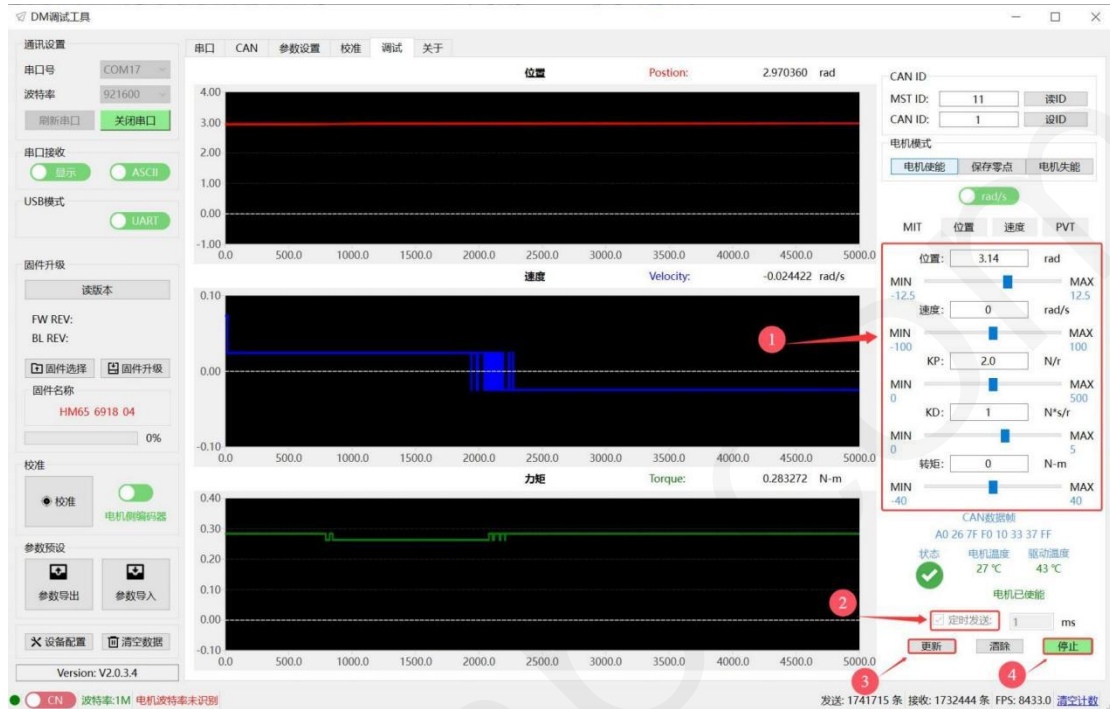

To debug, modify the control parameters and monitor changes. Edit parameters directly in the original interface, keep the 'Scheduled Send' option checked, then click 'Update' to proceed.

The debugging assistant interface displays real-time temperature data and operational status of the motor and drive. The feedback frame can also be viewed for details. For the format and types of feedback frames, please refer to the '4.1 Feedback Frame' section.

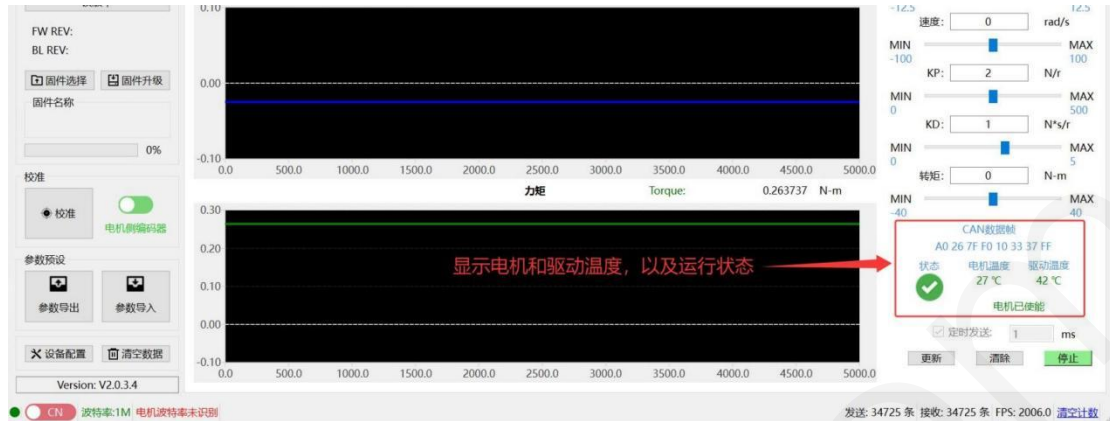

Step 3: To exit debug mode, first stop the motor, then sequentially press the "Stop" and "Disable" buttons. The driver's red light will illuminate, indicating the motor mode has been exited.

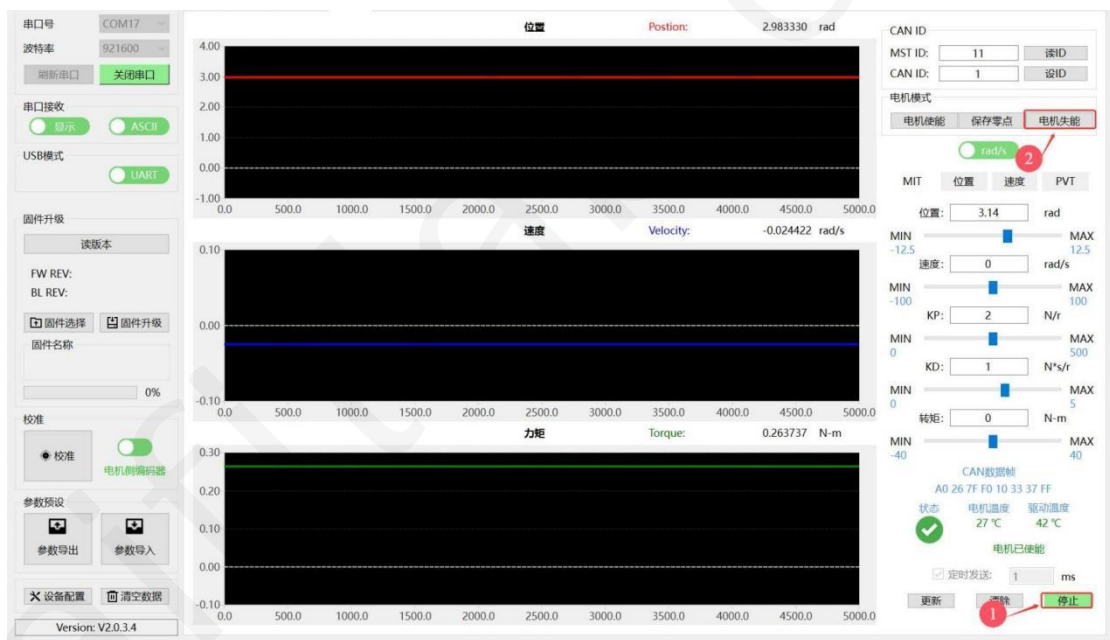

③ MIT torque control

Step 1: Click the Enable button in the motor mode bar. The driver's green light will turn on, indicating the motor is enabled.

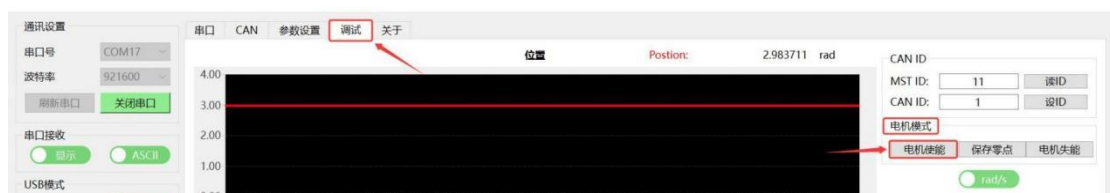

Second, the motor is debugged with the given torque.

Note: When unloaded, the motor will accelerate to maximum speed even with a minimal torque.

For example, set the torque to 1N-m with all other parameters at 0, check the 'Scheduled Send' box, then click 'Update' and 'Send' buttons in sequence. The parameter curve changes will appear in the debugging interface. Note: Keep the motor stationary.

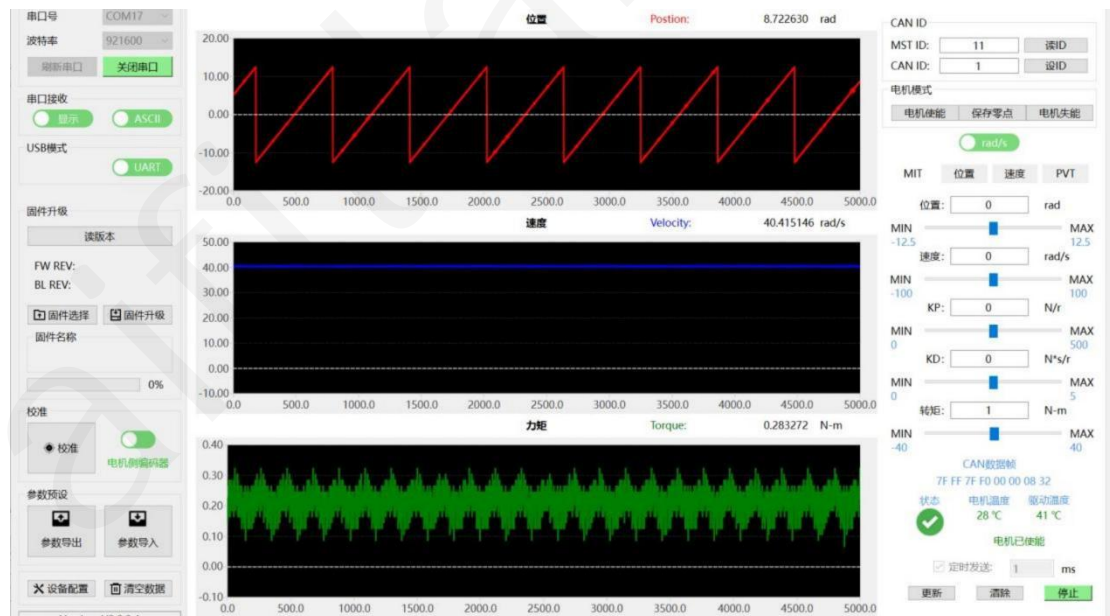
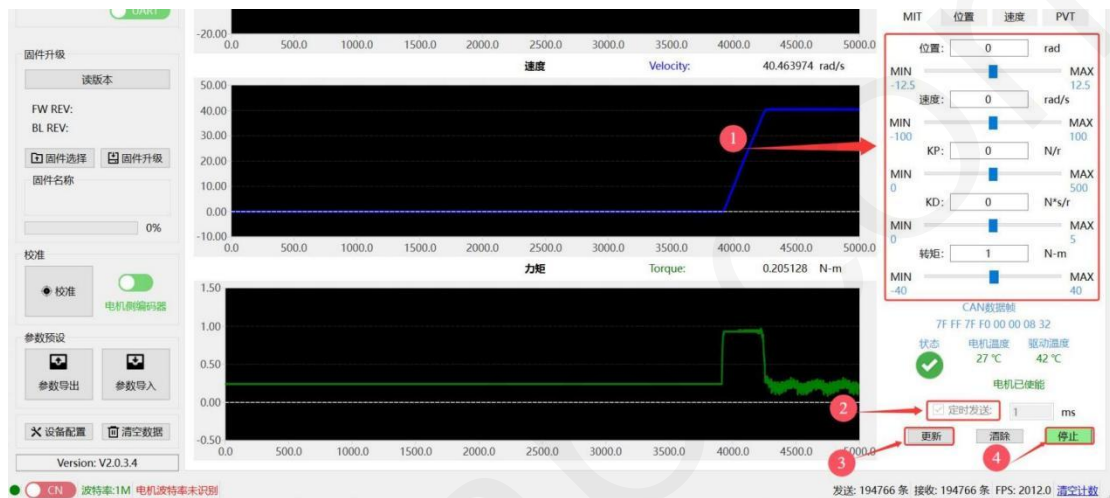

To debug, modify the control parameters to observe changes. Edit the parameters directly in the original interface, keep the 'Scheduled Send' option checked, and click the 'Update' button to proceed.

The debugging assistant interface displays real-time temperature data and operational status of the motor and drive. The feedback frame can also be viewed for details. For the format and types of feedback frames, please refer to the '4.1 Feedback Frame' section.

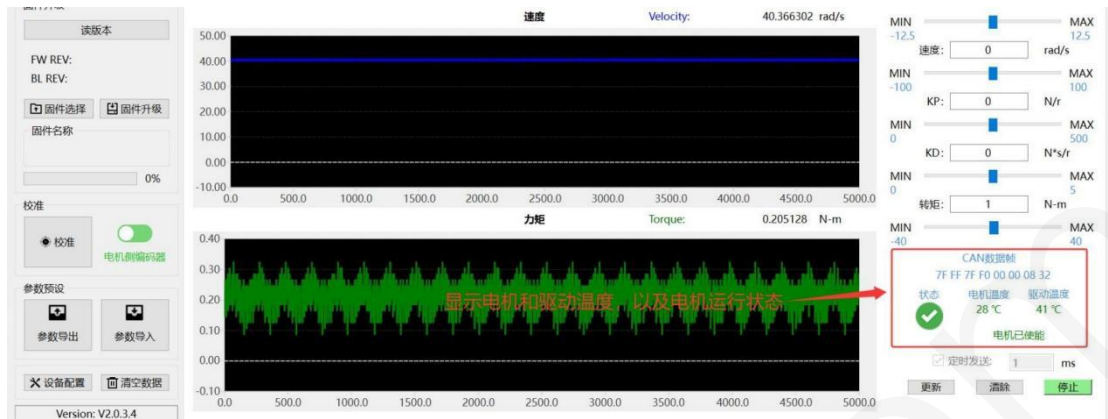

Step 3: To exit debug mode, click the "Stop" and "Enable" buttons in sequence. The red light on the drive will turn on, indicating the motor mode has been exited.

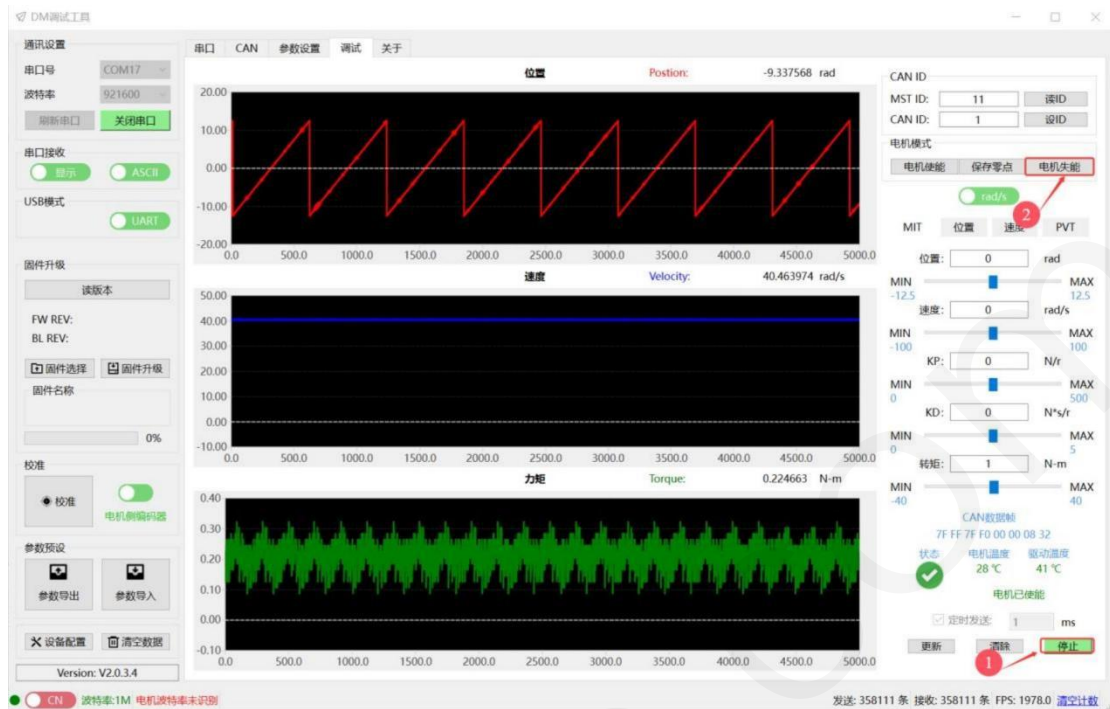

3. Position Velocity Mode

(4) To debug the position-speed mode, switch the motor mode to position-speed mode on the parameter page, then click 'Write Parameters' to apply the changes. Select the corresponding 'Position' sub-tab in the debugging interface.

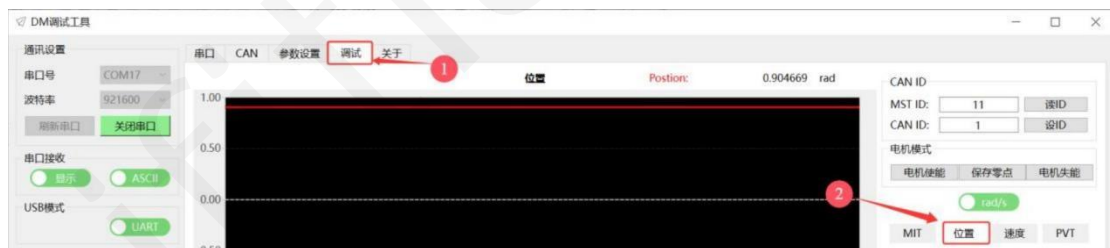

(5) Verify the CAN ID is correct (available through serial port printing, parameter settings, or debugging interface settings).



(6) Click the "Enable" button in the motor mode section. The driver's green light will illuminate, indicating the motor is now enabled.



(7) Set the parameters, then the motor will operate at the preset speed to reach the designated position.

Before setting parameters, note the motor's initial position to use as a reference.

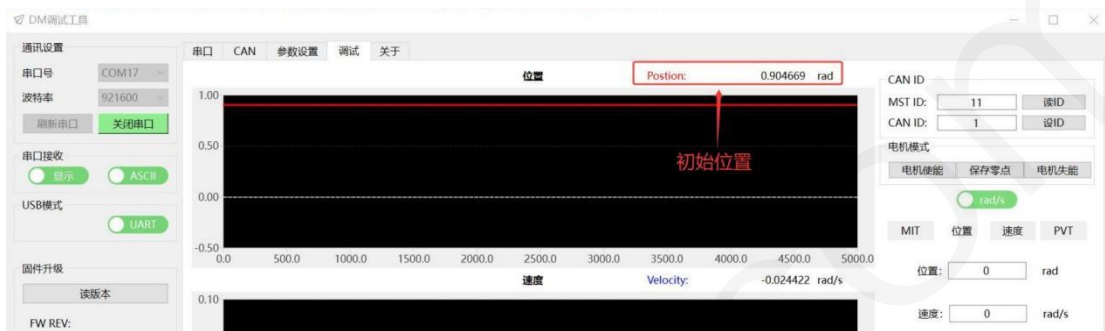

For example, set the parameters: position at 10 rad, speed at 5 rad/s. Check the 'Scheduled Send' box, then click 'Update' and 'Send' buttons in sequence to view the parameter curve changes in the debugging interface. Note: Keep the motor stationary.



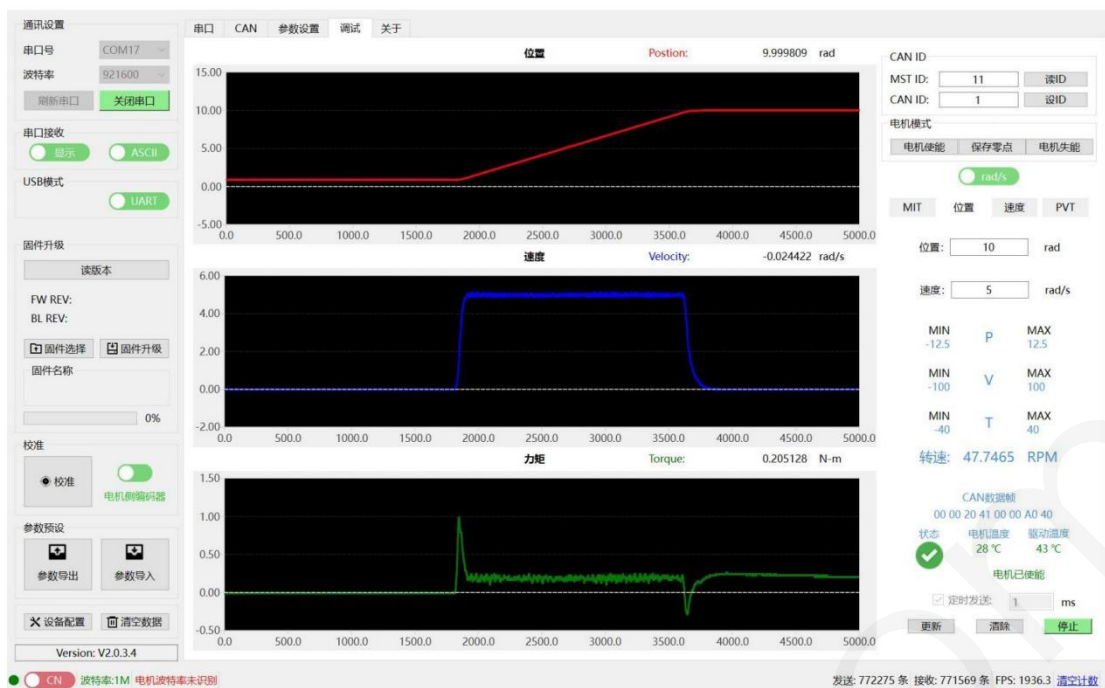

To debug, modify the control parameters and monitor changes. Edit parameters directly in the original interface, keep the 'Scheduled Send' option checked, then click 'Update' to proceed.

The debugging assistant interface displays real-time temperature data and operational status of the motor and drive. The feedback frame can also be viewed for details. For the format and types of feedback frames, please refer to the '4.1 Feedback Frame' section.

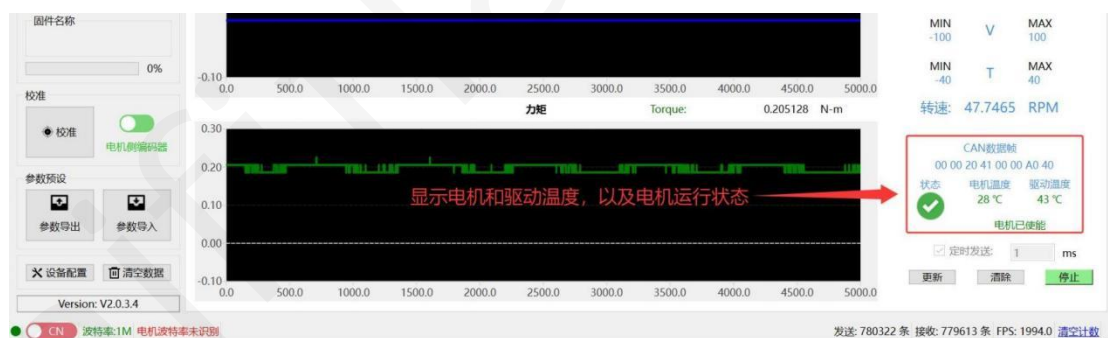

(8) To exit debug mode, press the "Stop" and "Disable" buttons in sequence. The driver's red light will illuminate, indicating the motor mode has been exited.

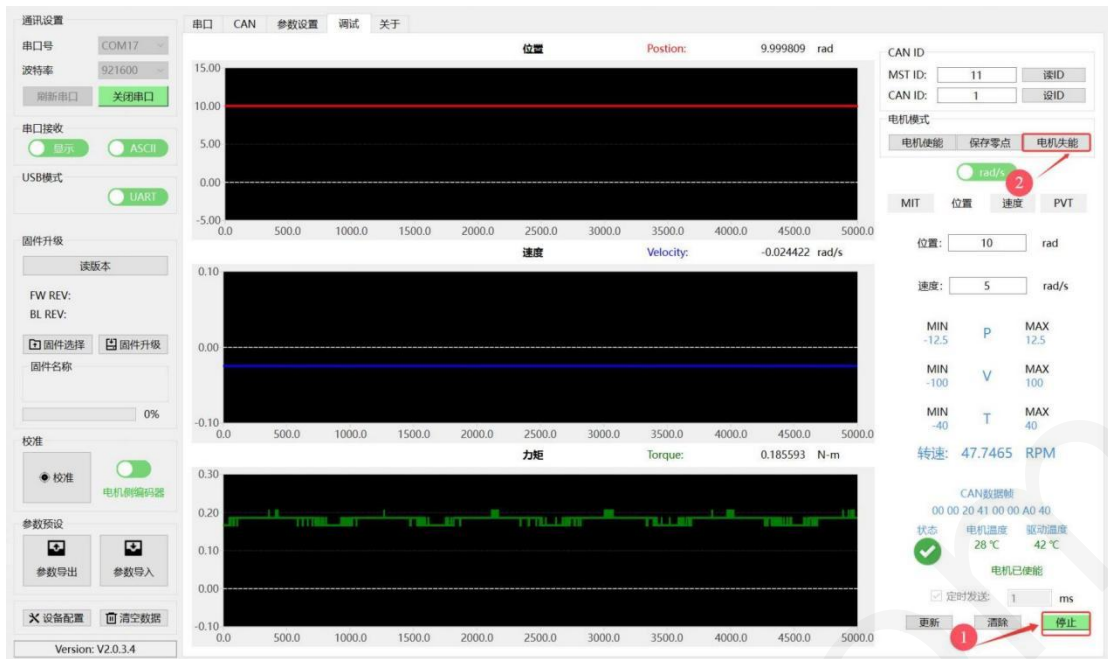

4. Speed Mode

(1) Select the speed mode as the current control mode by confirming the reference control mode selection, then choose the corresponding 'Speed' sub-tab card on the debugging page.

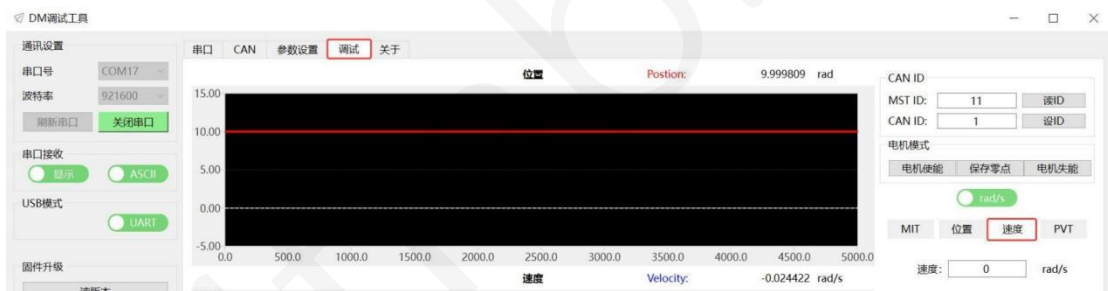

(2) Verify the CAN ID is correct (available through serial port printing, parameter settings, or debugging interface settings).



(3) Click the "Enable" button in the motor mode section. The driver's green light will illuminate, indicating the motor is now enabled.



(4) Set the parameters, and the motor will operate at the preset speed.

For example, set the parameter to 5 rad/s. Check the 'Scheduled Send' box, then click the 'Update' and 'Send' buttons in sequence to view the parameter curve changes in the debugging interface. Note: Keep the motor stationary.

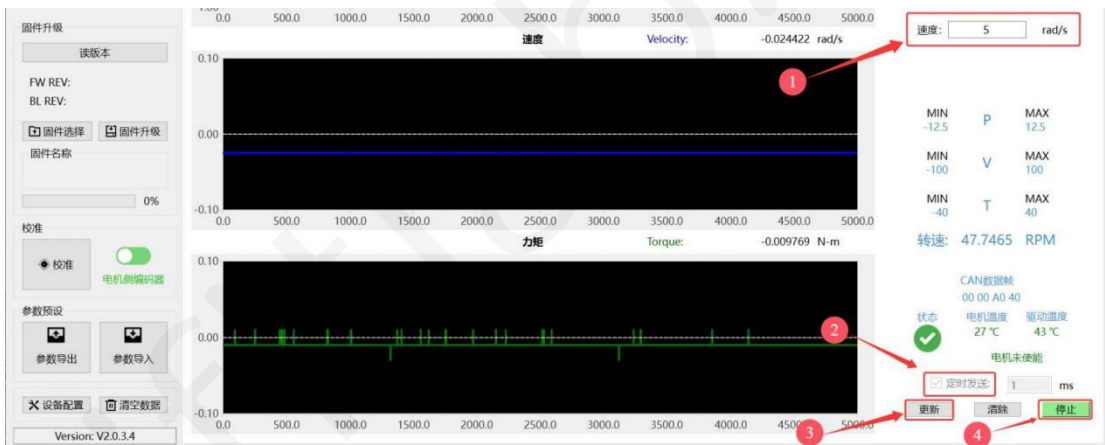

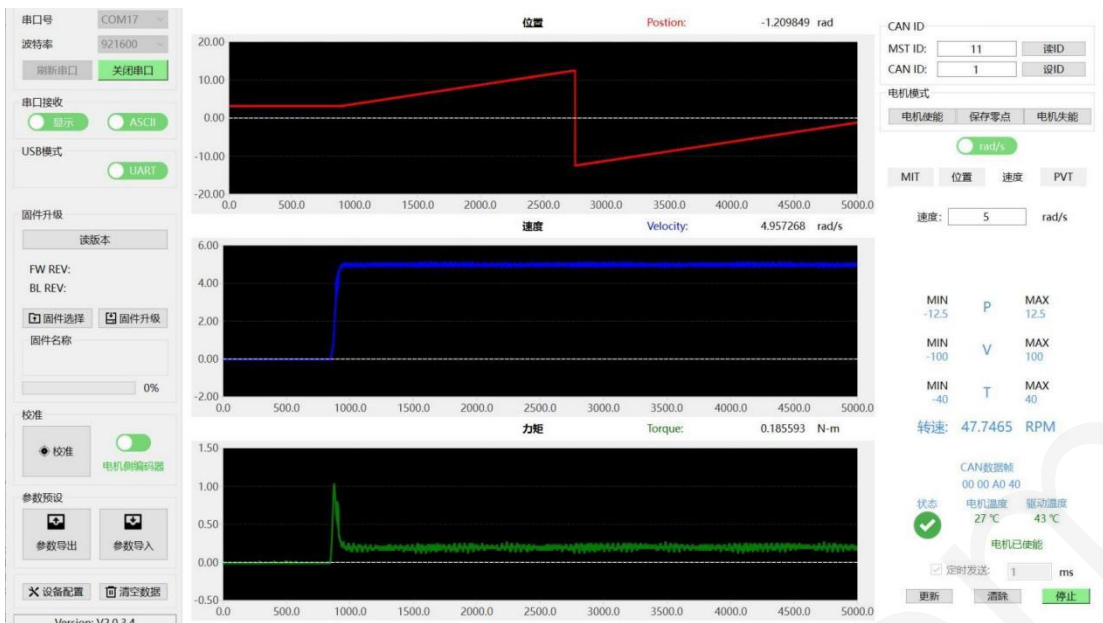

To debug, modify the control parameters and monitor changes. Edit parameters directly in the original interface, keep the 'Scheduled Send' option checked, then click 'Update' to proceed.

The debugging assistant interface displays real-time temperature data and operational status of the motor and drive. The feedback frame can also be viewed for details. For the format and types of feedback frames, please refer to the '4.1 Feedback Frame' section.

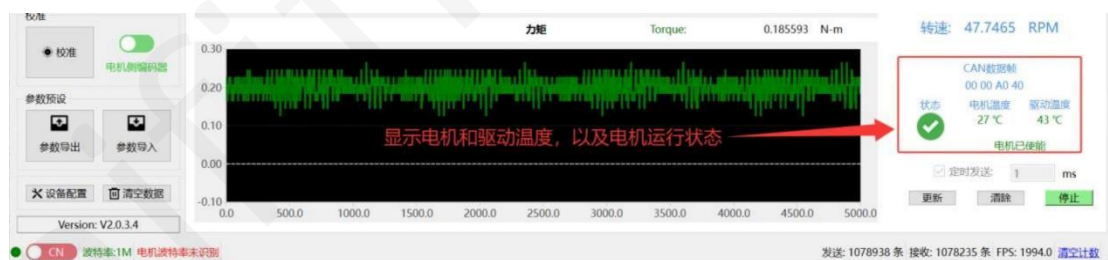

(5) To exit debug mode, first set the speed to 0 to stop the motor, then sequentially press the "Stop" and "Disable" buttons. The driver's red light will illuminate, indicating the motor mode has been exited.

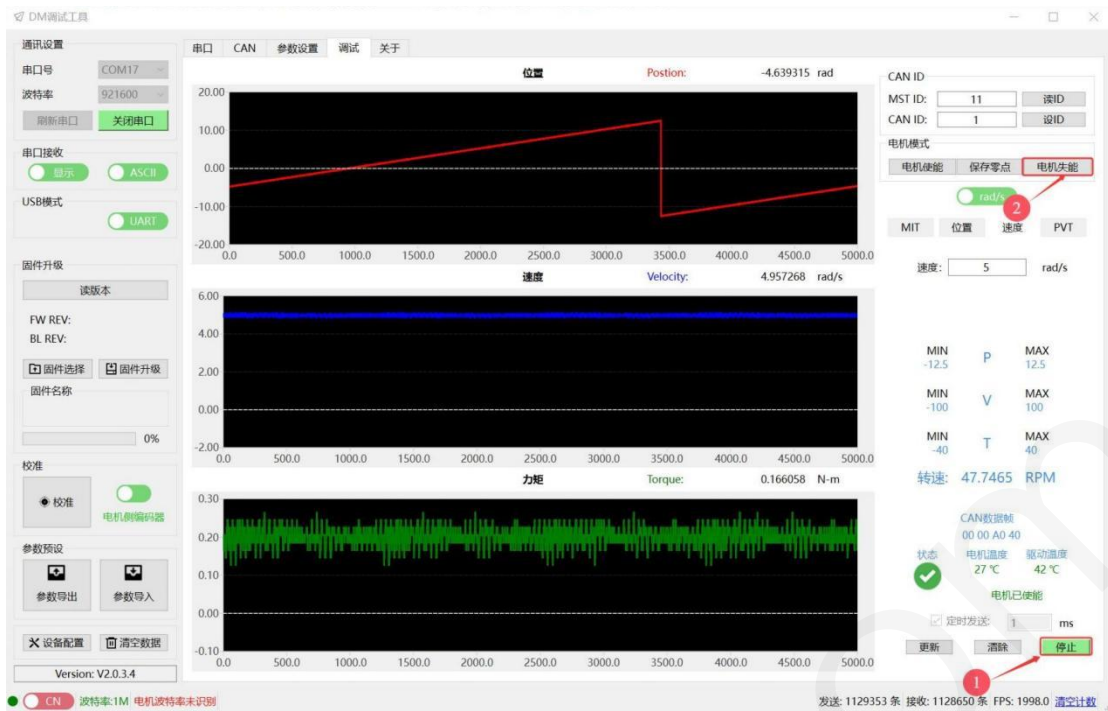

5. Force-position hybrid control mode

(1) To debug the force-position hybrid control mode, switch the motor mode to PVT mode on the parameter page, then click 'Write Parameters' to apply the changes. Select the corresponding 'Position' sub-tab in the debugging interface.



(2) Verify the CAN ID is correct (available through serial port printing, parameter settings, or debugging interface settings)



(3) Click the "Enable" button in the motor mode section. The driver's green light will illuminate, indicating the motor is now enabled.



(4) Set the parameters, then the motor will operate at the preset speed to reach the designated position.

Before setting parameters, note the motor's initial position to use as a reference.



For example, set the parameters as follows: position 10 rad, speed 5 rad/s, and current 20%. Check the 'Scheduled Send' box, then click the 'Update' and 'Send' buttons in sequence to view the parameter curve changes in the debugging interface. Note: Keep the motor stationary.

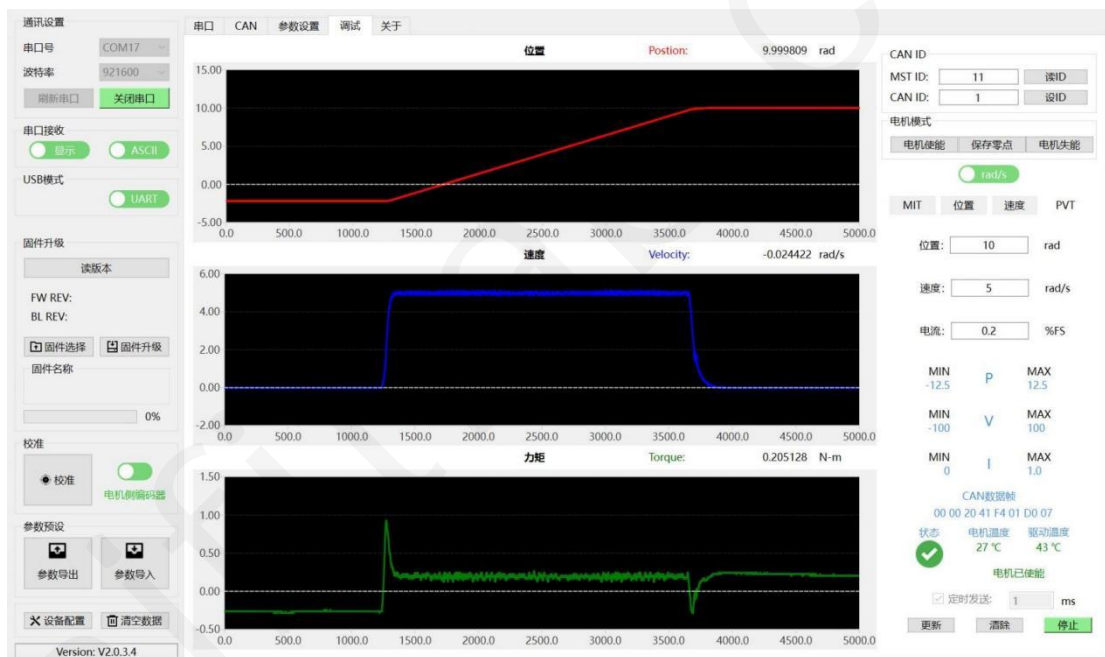

To debug, modify the control parameters and monitor changes. Edit parameters directly in the original interface, keep the 'Scheduled Send' option checked, then click 'Update' to proceed.

The debugging assistant interface displays real-time temperature data and operational status of the motor and drive. The feedback frame can also be viewed for details. For the format and types of feedback frames, please refer to the '4.1 Feedback Frame' section.

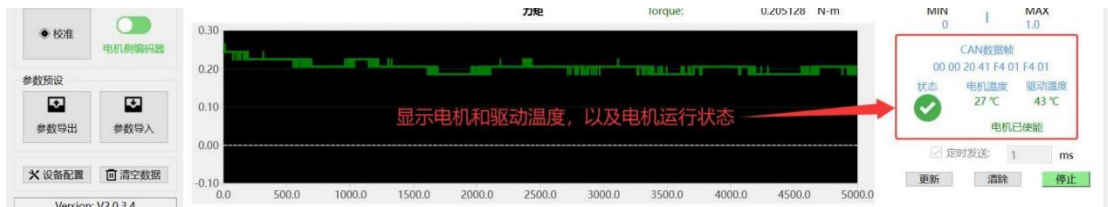

(5) To exit debug mode, first ensure the motor stops, then sequentially press the "Stop" and "Disable" buttons. The driver's red light will illuminate, indicating the motor mode has been exited.

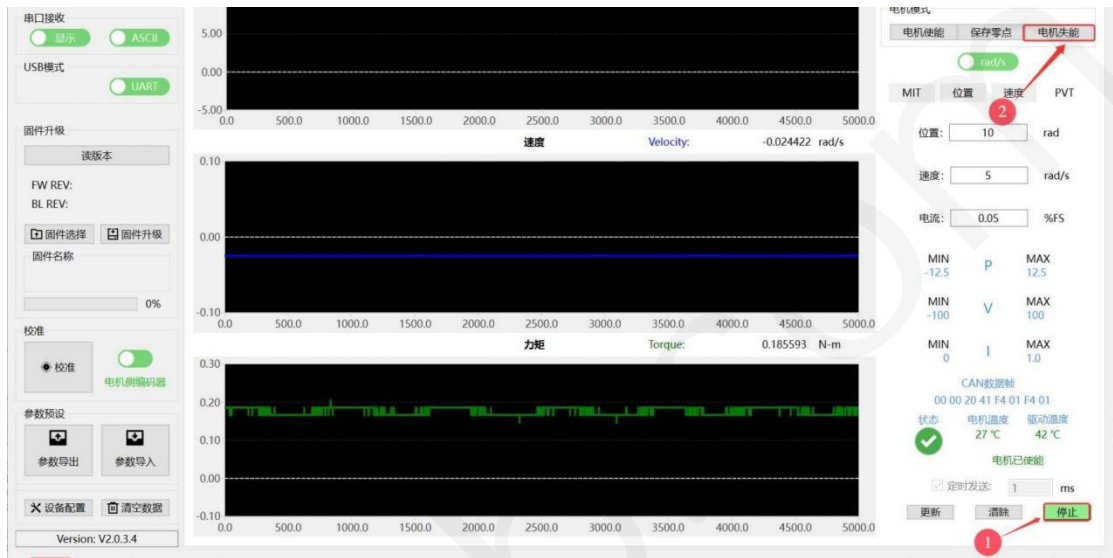

View and upgrade firmware version

Version view

Connect the motor's serial port, CAN port, and power interface. Select the appropriate serial port device and enable it. Click 'Read Version' to view the current driver software version number.

Before upgrading the firmware, read the current version. Unless otherwise specified, select firmware with a version number starting with 69 for upgrading. Otherwise, unknown issues may occur, causing unnecessary trouble.



The screenshot shows a software interface for communication and firmware upgrade. It is divided into several sections:

- 通讯设置 (Communication Settings):** Includes dropdown menus for '串口号' (COM3) and '波特率' (921600). Below are buttons for '刷新串口' (Refresh Serial Port) and '关闭串口' (Close Serial Port).
- 串口接收 (Serial Port Reception):** Features two toggle switches: '显示' (Display) and 'ASCII', both currently turned on.
- USB模式 (USB Mode):** Features a toggle switch for 'UART', which is currently turned on.
- 固件升级 (Firmware Upgrade):** Contains a '读版本' (Read Version) button and a table displaying the current firmware and bootloader versions.

固件升级	
读版本	
FW REV:	6.9.1.8
BL REV:	3.2.0.6

Serial firmware upgrade

When new firmware features are added or bug fixes are released, users can perform upgrades via the serial port to resolve issues and access new functionalities. First, connect the serial port and select the desired firmware by clicking "Firmware Selection". After clicking "Open", the firmware name will appear in the name field. Confirm the selection and click the firmware upgrade button. Wait for the progress bar to complete, or monitor the upgrade status through the serial port interface.

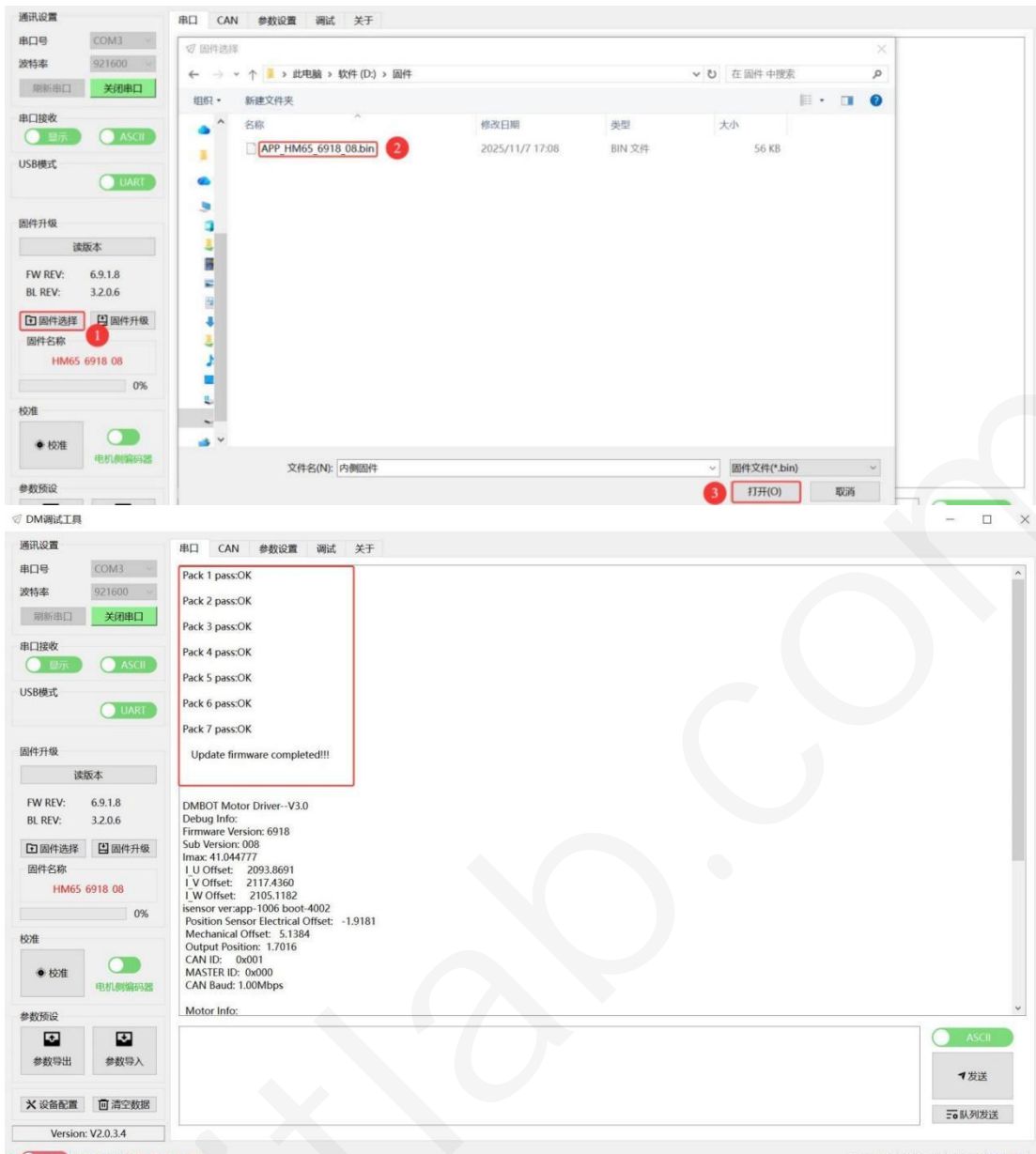

CAN firmware upgrade

The Bootloader version 3.2.0.5 and above supports CAN-based firmware upgrades at the driver board's configured baud rate, including USB-to-CAN and USB-to-CAN FD upgrades. Before use, connect the CAN bus to verify communication. In USB mode, switch UART to CAN and enter the motor ID to be upgraded in the left field. If the bus is unavailable, the system will display the following prompt:

DM调试工具

串口 CAN 参数设置 调试 关于

DMBOT Motor Driver-V3.0
Debug Info:
Firmware Version: 6918
Sub Version: 008
Imax: 41.044777
I_U Offset: 2093.6382
I_V Offset: 2117.2810
I_W Offset: 2105.2920
isensor ver:app-1006 boot-4002
Position Sensor Electrical Offset: -1.9181
Mechanical Offset: 5.1384
Output Position: 1.7016
CAN ID: 0x001
MASTER ID: 0x000
CAN Baud: 1.00Mbps

Motor Info:
Rs = 422.9736 mΩ
Ls = 766.9343 μH
ΨF = 0.0249 Wb
V_BUS=24.0289

Control Mode:
1:MIT Mode ←---
2:position-speed cascade Mode
3:speed Mode
4:Hybrid control Mode

Commands:
m - Motor Mode
s - Setup Mode
esc - Exit to Menu

提示
总线 ID: 0x03 不存在。
总线设备数量为 1, ID: 0X01
OK

固件升级
读版本
FW REV: 6.9.1.8
BL REV: 3.2.0.6
固件选择 固件升级
固件名称
HM65 6918 08
0%

校准
校准 电机编码器

参数预设
参数导出 参数导入
设备配置 清空数据
Version: V2.0.3.4

发送: 1267 条 接收: 6 条 FPS: 0.0 清空计数

串口设置
串口号 COM3
波特率 921600
刷新串口 关闭串口
串口接收
显示 ASCII
USB模式
CAN ID: 1 CAN
固件升级
校准
参数预设
设备配置

发送 队列发送

发送: 1267 条 接收: 6 条 FPS: 0.0 清空计数

No prompt is displayed if the connection is successful.

Next, click 'Firmware Selection' to choose the required firmware. After clicking 'Open', the firmware name will appear in the name field. Confirm the name is correct, then click the firmware upgrade button. Wait for the progress bar to complete, or check the upgrade status through the serial port interface.

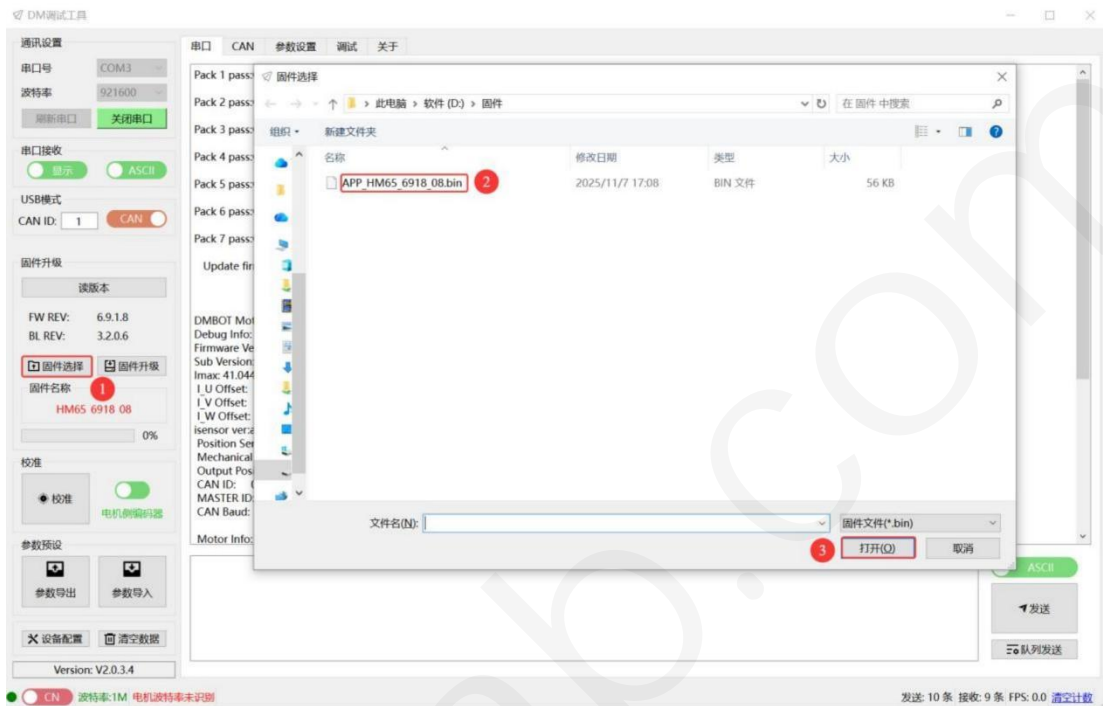

After the upgrade is complete, the serial interface will display the corresponding prompt:

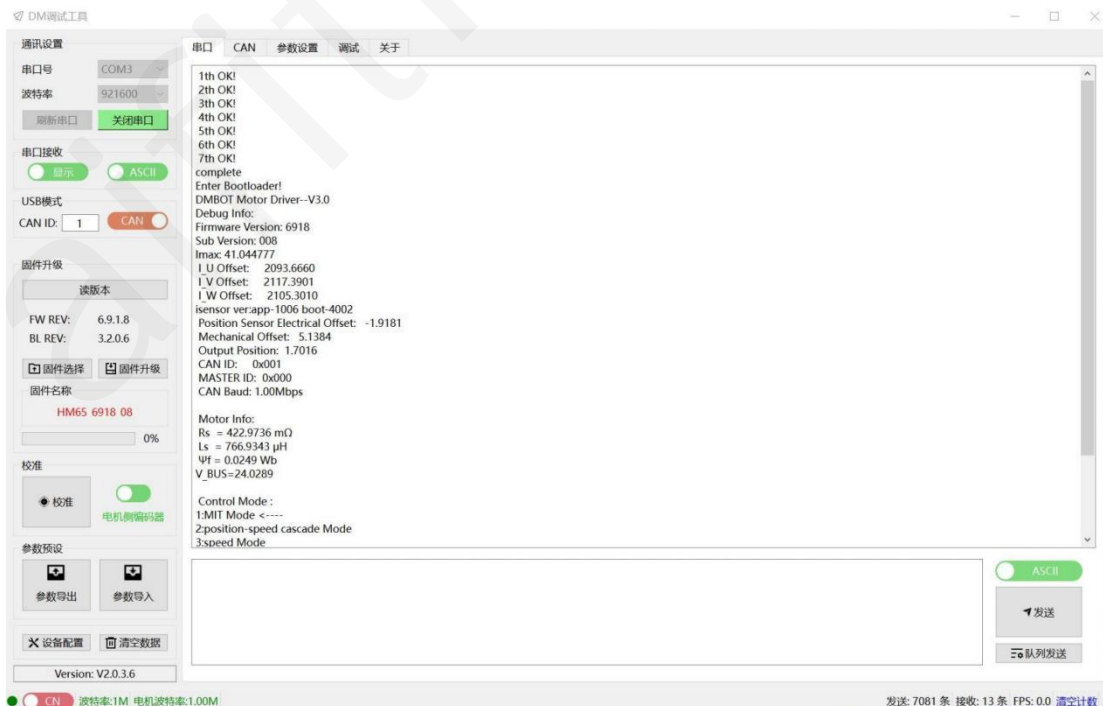

Efficiency curve

24V efficiency curve:

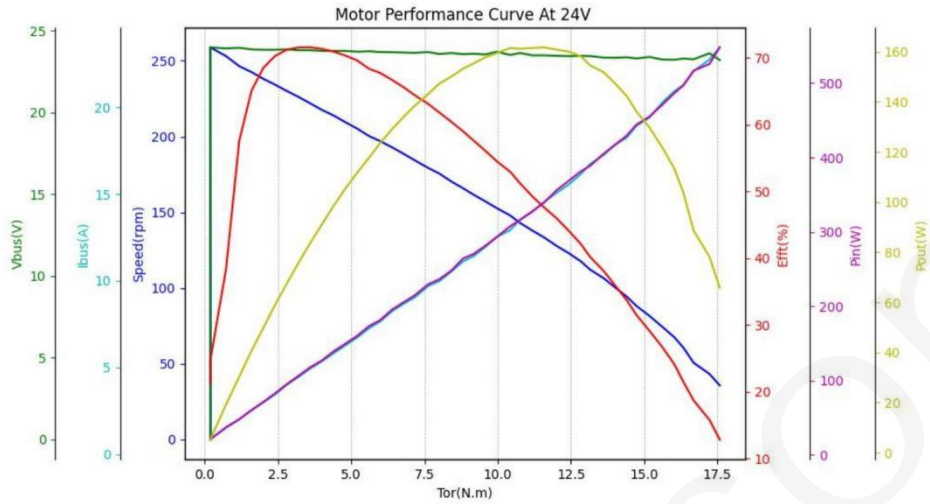

36V efficiency curve:

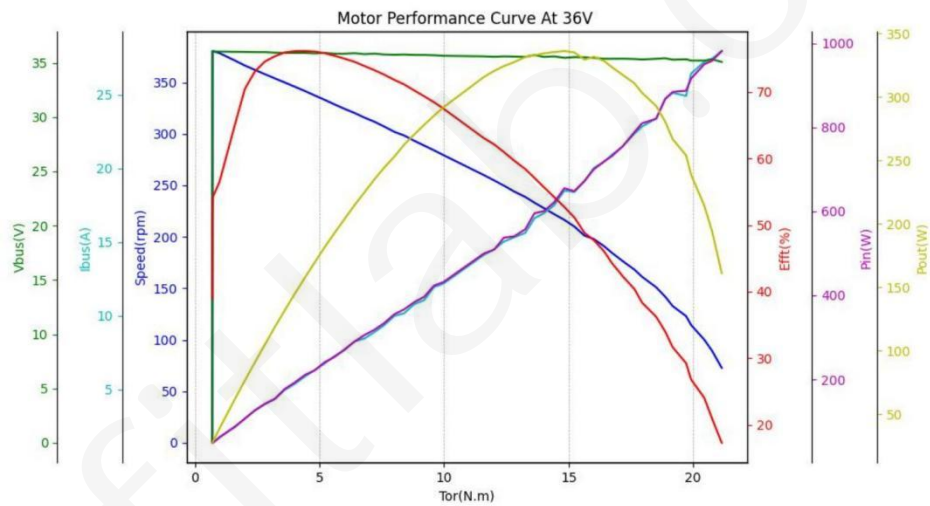

48V efficiency curve:

