

# DM-J8009P-2EC Geared Motor (Crossed Roller Bearing)

User Manual V1.0 2024.8.26



---

## Disclaimer

Thank you for purchasing the DM-J8009P-2EC geared motor (hereinafter referred to as “ the motor ” ).

Before using this product, please read this document and all provided safety instructions carefully and follow them strictly. Failure to do so may result in injury to yourself or others, or cause damage to this product or surrounding property. By using this product, you are deemed to have read, understood, acknowledged, and accepted all the terms and content of this manual and all related documentation.

You agree to use this product only for legitimate purposes and to take full responsibility for any consequences resulting from its use.

The manufacturer assumes no responsibility for any damage, injury, or legal liability caused directly or indirectly by the use of this product.

## Precautions

1. Operate the motor strictly within the specified working environment and the maximum allowable winding temperature range. Failure to comply may cause permanent and irreversible damage to the product.
2. Prevent foreign objects from entering the rotor; otherwise, abnormal rotor operation may occur.
3. Before use, inspect all components for integrity. Do not use the motor if any parts are missing, aged, or damaged.
4. Ensure proper wiring and secure installation of the motor.
5. Do not touch the electronic rotor section during operation to avoid accidents. The motor may become hot during high-torque output—be cautious to avoid burns.
6. Do not disassemble the motor without authorization, as this may affect control accuracy or lead to abnormal operation.

## Motor Features

1. Dual encoders provide single-turn absolute position output of the output shaft, ensuring no loss of position even after power failure.
  2. Integrated motor and driver design with a compact and highly integrated structure.
  3. Supports upper-computer visual debugging and firmware upgrades.
  4. Capable of providing feedback on motor speed, position, torque, and temperature via the CAN bus.
  5. Equipped with dual temperature protection.
  6. Supports trapezoidal acceleration and deceleration in position control mode.
-

## Packing List

1. Motor (with driver) x1
2. Power Cable: XT30 male-to-female power cable x1
3. CAN Communication Terminal: GH1.25 2-pin cable x1
4. Debug Serial Signal Cable: GH1.25 3-pin cable x1

## Interface and Wiring Description

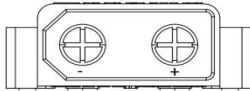
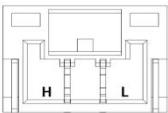
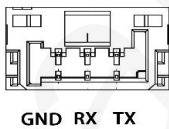
Specific Name – Number	Interface Label	Description
Power Connection Port-1		Connect the power supply via the XT30 male-to-female power cable. The rated voltage is 24V (supports 24 – 48V), which supplies power to the motor.
CAN Communication Terminal-2		Connect external control devices via the CAN terminal. The motor can receive CAN control commands and send feedback about its status.
Debug Serial Port-3		Connect via GH1.25 3-pin cable. Use a USB to CAN debugging tool (or a general USB-to-serial module) to connect to a PC for parameter configuration and firmware upgrades using the debugging assistant.

## Motor Dimensions and Installation

Please refer to the motor's mounting hole dimensions and positions to install the motor onto the corresponding equipment.

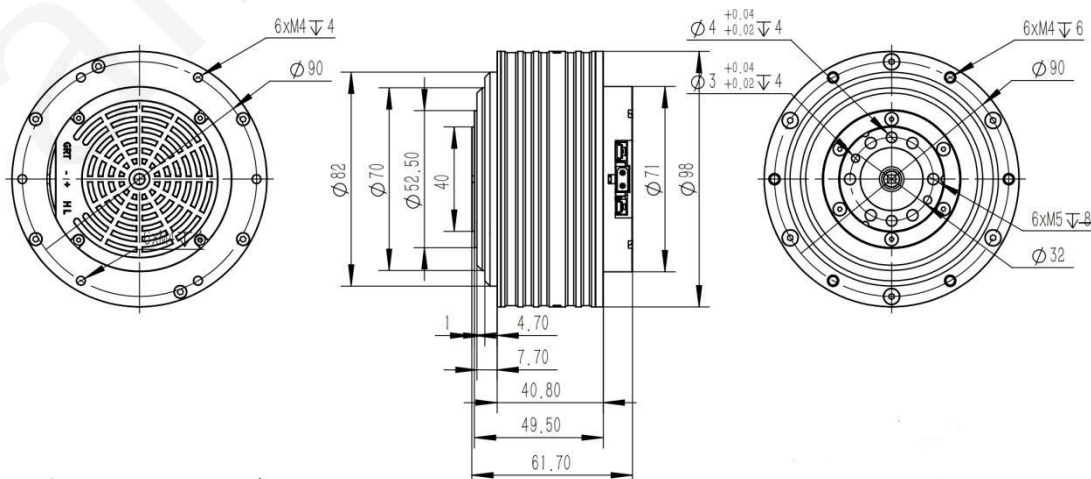

## Indicator Light Status

Normal Status	Green LED solid on	When ERR bit = 1, it indicates enabled mode, i.e., normal operating status.
	Red LED solid on	When ERR bit = 0, it indicates disabled mode.
Abnormal Status	Red LED blinking	<p>Indicates fault</p> <p>Corresponding fault types:</p> <p>8 — Overvoltage</p> <p>9 — Undervoltage</p> <p>A — Overcurrent</p> <p>B — MOS Overtemperature</p> <p>C — Motor Coil Overtemperature</p> <p>D — Communication Loss</p> <p>E — Overload</p> <p>Fault information can be checked via the feedback frame or displayed on the debugging assistant interface.</p>

## Operating Modes

### ❖ MIT Mode

MIT mode is designed to be compatible with the original MIT protocol, enabling seamless switching while allowing flexible configuration of control ranges ( $P\_MAX$ ,  $V\_MAX$ ,  $T\_MAX$ ). The ESC converts the received CAN data into control variables to compute the torque value, which is then used as the current reference for the current loop. The current loop adjusts accordingly to achieve the target torque current.

Control block diagram:

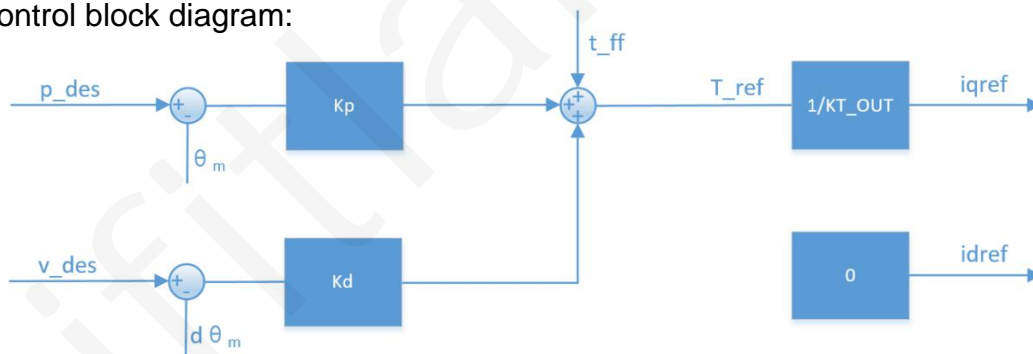

Various control patterns can be derived from MIT mode. For example:

If  $k_p = 0$ ,  $k_d = 0$ , setting  $v\_des$  achieves constant-speed rotation.

If  $k_p = 0$ ,  $k_d = 0$ , setting  $t\_ff$  achieves specified torque output.

*Note: When controlling position,  $k_d$  must not be set to 0; otherwise, motor oscillation or even loss of control may occur.*

### ❖ Position-Velocity Mode

Position-velocity cascade control adopts a three-loop structure. The position loop serves as the outer loop, whose output is the setpoint for the velocity loop. The velocity loop's output serves as the inner current loop's reference to control actual current output. The control block diagram is shown below:

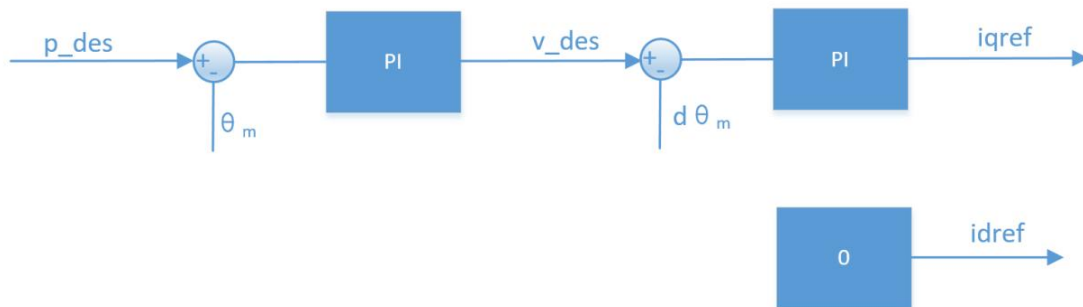

$p\_des$ : Target position

$v\_des$ : Maximum absolute speed during movement

When using control parameters recommended by the debugging assistant, this mode offers good control accuracy and relatively smooth operation, though the response time is longer. In addition to  $v\_des$ , acceleration/ deceleration values can be configured. If extra oscillation occurs during control, increasing the acceleration/deceleration may help.

**Note:**  $p\_des$  unit: rad,  $v\_des$  unit: rad/s, Data type: float, Damping factor must be set to a non-zero positive value, see velocity mode notes.

### ❖ Velocity Mode

Velocity mode allows the motor to maintain a stable, preset speed. The control block diagram is shown below:

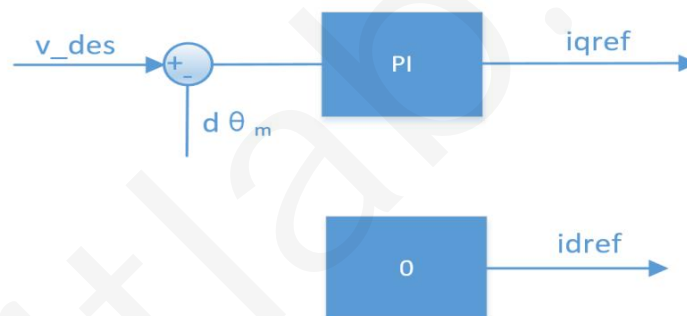

**Note:**

$v\_des$  unit: rad/s

Data type: float

To use the debugging assistant 's automatic parameter calculation, the damping factor must be set to a non-zero positive value.

Typical damping factor range: 2.0 – 10.0

Too low may cause oscillation and overshoot

Too high longer rise time

Recommended value: 4.0

### Usage

Control uses the CAN standard frame format with a fixed baud rate of 1 Mbps. Frames are divided into Receive Frames and Feedback Frames by function:

**Receive Frames:** carry control data received by the motor for executing commands

**Feedback Frames:** used by the motor to send status data to the upper-level controller

Depending on the selected motor mode, the Receive Frame format and Frame ID differ. However, the Feedback Frame format and data remain the same across all modes.

## ❖ Feedback Frame

The feedback frame ID is configured via the debugging assistant (Master ID), with a default value of 0. It primarily returns motor position, speed, and torque information. The frame format is defined as:

Feedback Frame	D[0]	D[1]	D[2]	D[3]	D[4]	D[5]	D[6]	D[7]
MST_ID	ID ERR<<4	POS[15:8]	POS[7:0]	VEL[11:4]	VEL[3:0] T[11:8]	T[7:0]	T_MOS	T_Rotor

Explanation:

ID: Controller ID, corresponds to the lower 8 bits of CAN\_ID

ERR: Fault code, corresponding to:

- 8 — Overvoltage
- 9 — Undervoltage
- A — Overcurrent
- B — MOS Overtemperature
- C — Motor Coil Overtemperature
- D — Communication Loss
- E — Overload

POS: Motor position information

VEL: Motor speed information

T: Motor torque information

T\_MOS: Average temperature of the MOSFETs on the driver (°C)

T\_Rotor: Average temperature of the motor coils (°C)

**Note:** Position, speed, and torque values are linearly mapped from floating-point to signed fixed-point format:

Position uses 16 bits

Speed and torque each use 12 bits

## ❖ Control Frame in MIT Mode

Control Message	D[0]	D[1]	D[2]	D[3]	D[4]	D[5]	D[6]	D[7]
ID	p_des [15:8]	p_des [7:0]	v_des [11:4]	v_des[3:0] Kp[11:8]	Kp [7:0]	Kd [11:4]	Kd[3:0] t_ff[11:8]	t_ff[7:0]

Frame ID: set CAN ID

P\_des: Position command

V\_des: Velocity command

Kp: Position proportional gain

Kd: Position derivative gain

T\_ff: Torque feedforward value

All parameters follow the mapping method mentioned in the previous section.

Ranges: p\_des, v\_des, t\_ff can be configured via the assistant

Kp: [0, 500]

Kd: [0, 5]

---

The standard CAN frame contains only 8 bytes.

MIT control frame packs five parameters (Position, Velocity, Kp, Kd, Torque) into 8 bytes:

Position: 16 bits

Velocity: 12 bits

Kp: 12 bits

Kd: 12 bits

#### ❖ Control Frame in Position-Velocity Mode

Control Message	D[0]	D[1]	D[2]	D[3]	D[4]	D[5]	D[6]	D[7]
0x100+ID	p_des				v_des			

Frame ID: CAN ID + 0x100 offset

P\_des: Position command, float, little-endian (low byte first)

V\_des: Velocity command, float, little-endian (low byte first)

This mode uses trapezoidal acceleration. The velocity command represents the maximum speed during the constant-speed phase.

#### ❖ Control Frame in Velocity Mode

Control Message	D[0]	D[1]	D[2]	D[3]
0x200+ID	v_des			

Frame ID: CAN ID + 0x200 offset

V\_des: Velocity command, float, little-endian (low byte first)

The CAN ID used to send commands in this mode is 0x200 + ID.

## Using the Debugging Assistant

Use the USB-to-CAN debugging tool to connect the motor to the PC, and configure motor parameters or upgrade firmware via the debugging assistant.

The motor's debug serial port is connected to the PC via GH1.25 3-pin cable

The CAN communication terminal is connected to the USB-to-CAN debugging tool via GH1.25 2-pin cable

After all interfaces—serial port, CAN port, and power—are connected:

1. Open the debugging assistant on the PC
  2. Select the appropriate serial device and open the port
  3. Power on the motor
  4. The serial monitor will output information, and Control Mode will indicate the current drive mode
-

## Characteristic Parameters

The DM-J8009P-2EC model features a crossed roller bearing on the output shaft. The DM-J8009-2EC model uses a thin-wall deep groove ball bearing on the output shaft.

<b>Motor Parameters</b>	Rated Voltage	24 V(Support 24-48V)
	Rated Phase (Power) Current	20 A
	Peak Phase (Power) Current	50 A
	Rated Torque	20 NM
	Peak Torque	40 NM
	Rated Speed	100rpm
	Max No-Load Speed	24V: 160rpm; 48V: 320rpm;
<b>Motor Characteristics</b>	Gear Ratio	9:1
	Pole Pairs	21
	Phase Inductance	80uh
	Phase Resistance	0.145Ω
<b>Structure &amp; Weight</b>	Outer Diameter	98 mm
	Height	61.7 mm
	Motor Weight	≈ 930 g
<b>Encoder</b>	Encoder Resolution	14-bit
	Number of Encoders	2
	Encoder Type	Magnetic encoder (single-turn, absolute output-shaft position)
<b>Communication</b>	Control Interface	CAN@1Mbps
	Tuning Interface	UART @ 921 600 bps
<b>Control &amp; Protection</b>	Control Modes	MIT mode / Velocity mode / Position mode
	Driver Over-temperature Protection (threshold)	120 °C — exits "enabled mode" when exceeded
	Motor Over-temperature Protection (user-set, recommended ≤ 100 °C)	Exits "enabled mode" when exceeded
	Motor Over-voltage Protection (user-set, recommended ≤ 52 V)	Exits "enabled mode" when exceeded
	Communication-loss Protection	If no CAN command within set period → exits "enabled mode"
	Motor Over-current Protection (user-set, recommended ≤ 39 A)	Exits "enabled mode" when exceeded
	Motor Under-voltage Protection (supply must be ≥ 15 V)	Exits "enabled mode" when below threshold