

DM-J8006-2EC Geared Motor

User Manual V1.1 2023.10.10



Disclaimer

Thank you for purchasing the DM-J8006-2EC geared motor (hereinafter referred to as "the motor").

Before using this product, please carefully read and follow the instructions in this document and all safety guidelines provided. Failure to do so may result in harm to yourself or others, or cause damage to the product or surrounding property.

By using this product, you are deemed to have read this document thoroughly and to have understood, acknowledged, and accepted all the terms and contents of this document and any related materials.

You agree to use this product only for legitimate purposes and assume full responsibility for its usage and any resulting consequences.

The manufacturer shall not be held liable for any damage, injury, or legal responsibility caused directly or indirectly by the use of this product.

Precautions

1. Please strictly operate the motor within the specified working environment and the maximum allowable winding temperature range. Failure to do so may result in permanent and irreversible damage to the product.
2. Prevent foreign objects from entering the rotor; otherwise, abnormal rotor operation may occur.
3. Before use, check whether all components are intact. Do not use the product if any parts are missing, aged, or damaged.
4. Ensure correct wiring and that the motor is installed properly and securely.
5. Do not touch the electronic rotor section during operation to avoid accidents. The motor may become hot during high-torque output; be cautious to prevent burns.
6. Users must not disassemble the motor without authorization, as this may affect control accuracy or lead to abnormal operation.

Motor Features

1. Dual encoders provide single-turn absolute position output on the output shaft, retaining position data even in the event of power loss.
 2. Integrated motor and driver design with a compact and highly integrated structure.
 3. Supports upper-computer visual debugging and firmware upgrades.
 4. Capable of providing feedback on motor speed, position, torque, and temperature via CAN bus.
 5. Equipped with dual temperature protection.
 6. Supports trapezoidal acceleration and deceleration in position control mode.
-

Packing List

Motor (with integrated driver) ×1
 Power Cable: XT30 Male-to-Female Power Cable ×1
 CAN Communication Terminal: GH1.25 2-pin Cable ×1
 Debug Serial Signal Cable: GH1.25 3-pin Cable ×1

Interface and Wiring Description

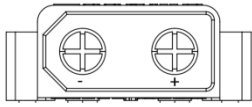
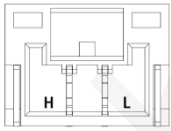
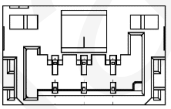
Specific Name – Number	Interface Label	Description
Power Connection Port – 1		Connect the power supply using an XT30 male-to-female power cable. Rated voltage: 24V (supports 24 – 48V). This provides power to the motor.
CAN Communication Terminal – 2		Connect to an external control device via the CAN communication terminal to receive CAN communication commands and send motor status feedback.
Debug Serial Port – 3	 GND RX TX	Connect via GH1.25 3-pin cable. Use a USB to CAN debugging tool (or a general USB-to-serial module) to connect to a PC for parameter configuration and firmware upgrades via the debugging assistant.

Motor Dimensions and Installation

Please refer to the motor mounting hole dimensions and positions to install the motor onto the corresponding equipment.

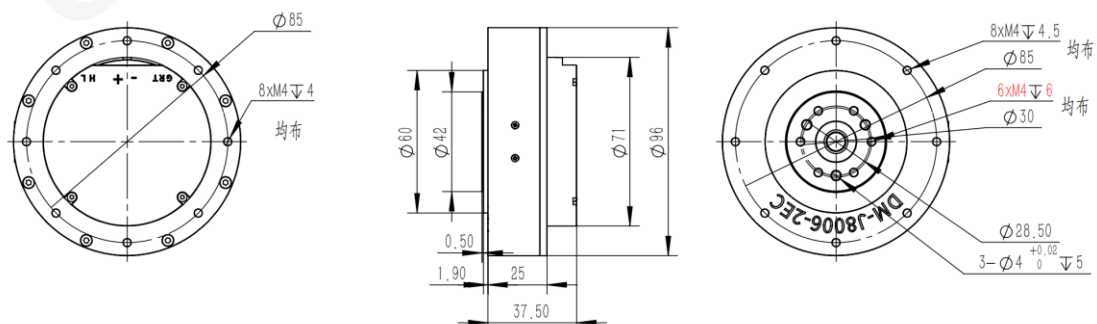

Indicator Light Status

Normal Status	Green-Solid On	ERR bit is 1, indicating enabled mode and normal operating status
	Red-Solid On	Disabled mode
Abnormal Status	Red – Blinking	Indicates a fault. Corresponding fault types include: 8 – Overvoltage 9 – Undervoltage A – Overcurrent B – MOS Overtemperature C – Motor Coil Overtemperature D – Communication Loss E – Overload You can check the fault type via the feedback frame or through the debugging assistant interface.

Operating Modes

❖ MIT Mode

MIT mode is designed to be compatible with the original MIT mode. It allows seamless switching while enabling flexible configuration of control ranges (P_MAX , V_MAX , T_MAX). The ESC converts received CAN data into control variables to calculate the torque value, which serves as the current reference for the current loop. The current loop then regulates to achieve the specified torque current.

The control block diagram is as follows:

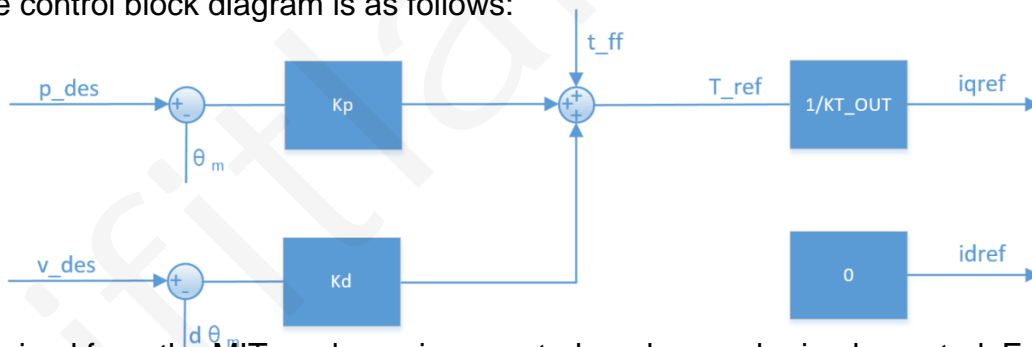

Derived from the MIT mode, various control modes can be implemented. For example:

When $k_p = 0$ and $k_d \neq 0$, setting v_des enables constant speed rotation;

When $k_p = 0$ and $k_d = 0$, setting t_ff enables constant torque output.

Note:

When controlling position, k_d must not be set to 0, otherwise it may cause motor oscillation or even loss of control.

❖ Position-Velocity Mode

The position-velocity mode uses a three-loop cascaded control scheme. The position loop serves as the outermost loop, and its output is the setpoint for the velocity loop. The velocity loop's output is used as the setpoint for the inner current loop, which controls the actual current output. The control block diagram is as follows:

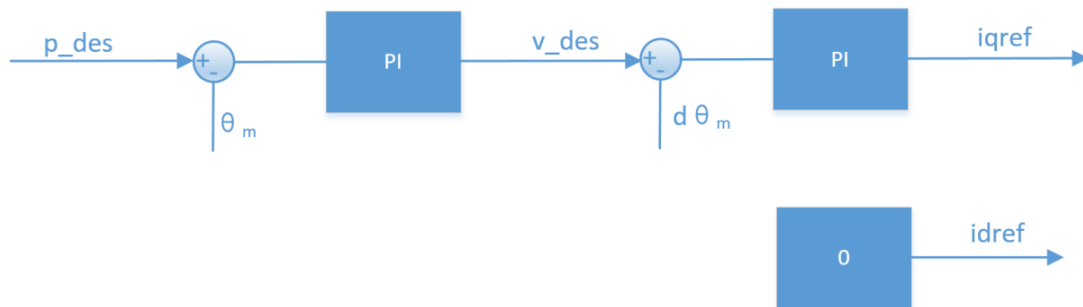

p_des is the target position to be controlled, and v_des is used to limit the maximum absolute velocity during the movement.

When using the recommended control parameters in the tuning assistant, the cascaded position control mode can achieve good control accuracy and relatively smooth motion, although the response time may be longer. In addition to v_des , configurable parameters also include acceleration and deceleration. If oscillation occurs during the control process, increasing the acceleration/deceleration values may help.

Note: The units of p_des and v_des are radians (rad) and radians per second (rad/s), respectively. Their data types are float. The damping factor must be set to a non-zero positive value. Please refer to the notes under the speed control mode for guidance.

❖ Velocity Mode

Velocity mode allows the motor to run steadily at the set speed. The control block diagram is as follows:

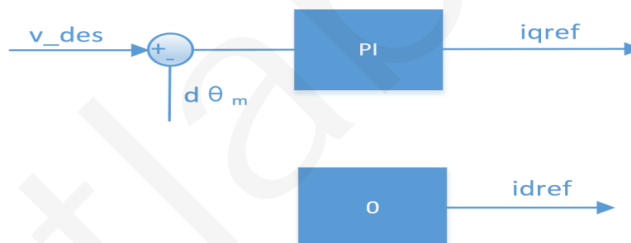

Note:

The unit of v_des is rad/s, and the data type is float.

To enable automatic parameter calculation using the debugging assistant, the damping factor must be set to a non-zero positive value.

Typically, it ranges from 2.0 to 10.0: A value that is too small may cause speed oscillation and significant overshoot. A value that is too large may result in a longer rise time. The recommended setting is 4.0.

Operation

The motor adopts the standard CAN frame format for control, with a fixed baud rate of 1 Mbps. According to function, frames are categorized into receive frames and feedback frames.

Receive frames are used to send control data to the motor for command execution.

Feedback frames are used by the motor to return its status data to the upper-level controller.

The receive frame format and corresponding frame ID differ depending on the motor's selected control mode, while the feedback frame format remains consistent across all modes.

❖ Feedback Frame

The Feedback Frame ID is configured via the debugging assistant (Master ID) and defaults to 0. It mainly reports the motor's position, speed, and torque .

The specific frame format is defined as:

Feedback Message	D[0]	D[1]	D[2]	D[3]	D[4]	D[5]	D[6]	D[7]
MST_ID	ID ERR<<4	POS[15:8]	POS[7:0]	VEL[11:4]	VEL[3:0] T[11:8]	T[7:0]	T_MOS	T_Rotor

ID: Controller ID, corresponding to the lower 8 bits of the CAN ID.

ERR: Status indicator, with types as follows:

- 8 – Overvoltage
- 9 – Undervoltage
- A – Overcurrent
- B – MOS overtemperature
- C – Motor coil overtemperature
- D – Communication lost
- E – Overload

POS: Motor position information *VEL: Motor speed information

*T: Motor torque information

*T_MOS: Average temperature of the MOSFETs on the driver board (unit: °C)

T_Rotor: Average temperature of the motor ' s internal coil (unit: °C)

* Position, speed, and torque are converted from floating-point to signed fixed-point

format using a linear mapping:

Position uses 16-bit data

Speed and torque use 12-bit data each

❖ Control Frame in MIT Mode

Control Message	D[0]	D[1]	D[2]	D[3]	D[4]	D[5]	D[6]	D[7]
ID	p_des [15:8]	p_des [7:0]	v_des [11:4]	v_des[3:0] Kp[11:8]	Kp [7:0]	Kd [11:4]	Kd[3:0] t_ff[11:8]	t_ff[7:0]

Frame ID is equal to the configured CAN ID value.

P_des: Position command

V_des: Velocity command

Kp: Position proportional gain

Kd: Position derivative gain

T_ff: Torque feedforward value

All parameters follow the mapping relationships described in the previous section. The ranges of p_des, v_des, and t_ff can be configured via the debugging assistant.

Kp range: [0, 500] Kd range: [0, 5]

A standard CAN data frame contains only 8 bytes.
 In MIT mode, the control command format packs five parameters — Position, Velocity, Kp, Kd, and Torque — into those 8 bytes.
 Position: 16 bits (2 bytes)
 Velocity: 12 bits
 Kp: 12 bits
 Kd: 12 bits

❖ Control Frame in Position-Velocity Mode

Control Message	D[0]	D[1]	D[2]	D[3]	D[4]	D[5]	D[6]	D[7]
0x100+ID	p_des				v_des			

Frame ID = configured CAN ID value + 0x100
 P_des: Position command, float, little-endian (low byte first, high byte last)
 V_des: Velocity command, float, little-endian (low byte first, high byte last)
 In this mode, the CAN ID used to send commands is 0x100 + ID. The velocity command defines the maximum speed during the movement to the target position—i.e., the speed during the constant-velocity phase.

❖ Control Frame in Velocity Mode

Control Message	D[0]	D[1]	D[2]	D[3]
0x200+ID	v_des			

Frame ID = configured CAN ID value + 0x200
 V_des: Velocity command, float, little-endian (low byte first, high byte last)
 In this mode, the CAN ID used to send commands is 0x200 + ID.

Using the Debugging Assistant

Use a USB-to-CAN debugging tool to connect the motor to the computer, and configure motor parameters or perform firmware upgrades via the debugging assistant.

The motor's debug serial port is connected to the PC via a GH1.25 3-pin cable, and the CAN communication terminal is connected to the USB-to-CAN debugging tool via a GH1.25 2-pin cable. Configuration and firmware upgrades can be performed through the debugging assistant.

Once the serial port, CAN port, and power interface are all connected, open the debugging assistant on the PC, select the corresponding serial device, and open the serial port. At this point, power on the motor—status information will be printed in the serial terminal, and the Control Mode will indicate the current drive mode.

Key Parameters

Please refer to the following parameters for proper motor usage:

Motor Parameters	Rated Voltage	24 V (Support 24-48V)
	Rated Phase (Power) Current	6.5 A
	Peak Phase (Power) Current	18 A
	Rated Torque	8 NM
	Peak Torque	20 NM
	Rated Speed	120rpm
	Max No-Load Speed	200rpm
Motor Characteristics	Gear Ratio	6:1
	Pole Pairs	21
	Phase Inductance	230uh (@25°C)
	Phase Resistance	0.36Ω(@25°C)
Structure & Weight	Outer Diameter	96 mm
	Height	40 mm
	Motor Weight	≈ 550 g
Encoder	Encoder Resolution	14-bit
	Number of Encoders	2
	Encoder Type	Magnetic encoder (single-turn)
Communication	Control Interface	CAN@1Mbps
	Tuning Interface	UART @ 921 600 bps
Control & Protection	Control Modes	MIT mode / Velocity mode / Position mode
	Driver Over-temperature Protection (threshold)	120 °C — exits "enabled mode" when exceeded
	Motor Over-temperature Protection (user-set, recommended ≤ 100 °C)	Exits "enabled mode" when exceeded
	Motor Over-voltage Protection (user-set, recommended ≤ 32 V)	Exits "enabled mode" when exceeded
	Communication-loss Protection	If no CAN command within set period → exits "enabled mode"
	Motor Over-current Protection (user-set, recommended ≤ 9.8 A)	Exits "enabled mode" when exceeded
	Motor Under-voltage Protection (supply must be ≥ 15 V)	Exits "enabled mode" when below threshold